

AGRICULTURAL MACHINERY

sitrex®
Spa

ASSEMBLY, USE AND MAINTENANCE

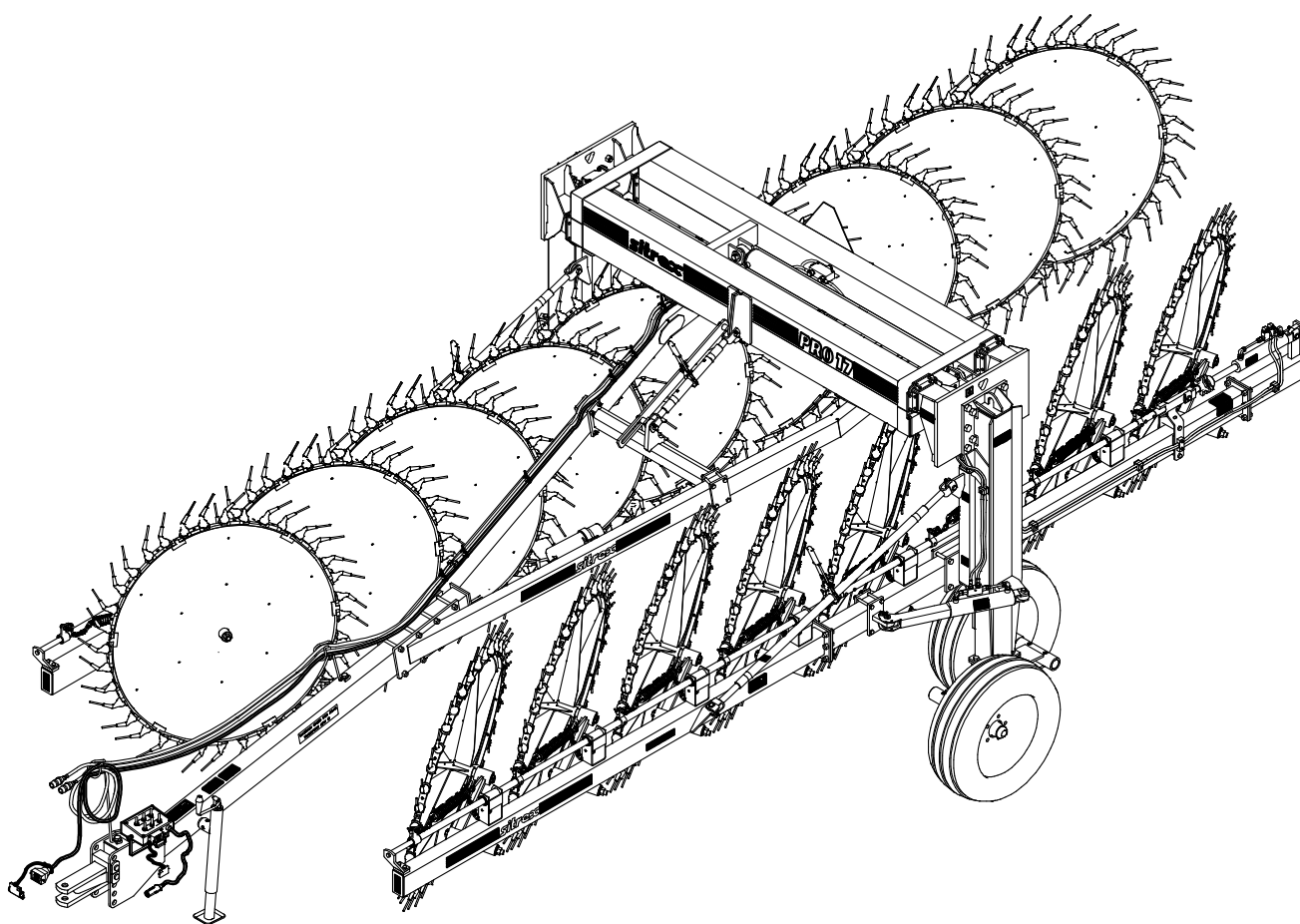

PRO/17

11/2011 (FROM SERIAL NUMBER 231764)

WARRANTY

On delivery, check that the machine has not been damaged during transport and that all the attachments are present. Claims must be made in writing to the agent within 8 days of receipt.

The manufacturer warrants new machinery at the time of delivery to the original purchaser to be free from defects in material and workmanship if properly set up and operated in accordance with this Operator's Manual.

The manufacturer undertakes to repair or replace free of charge any defective part which should be returned by the purchaser (freight prepaid) and found to be defective by inspection authorized by the manufacturer during the warranty period.

This warranty will be valid for 12 (twelve) months from the delivery of goods to the original purchaser .

In case the customer is not in a position to return the defective part to the manufacturer , the manufacturer cannot be held responsible for any cost due for repair or replacement of any part of the machine , he will only supply the part(s) required for the repair and/or replacement.

The warranty is null and void when it is evident that the machine has been improperly used or however repaired without authorization.

The manufacturer undertakes no responsibility for any obligation or agreement reached by any employers, agents or dealers, which are not in compliance with the above warranty . The manufacturer cannot be held responsible for the consequent damages. This warranty substitutes any other warranty , express or implied , and any other manufacturer's obligation.

NOTE: ALL WARRANTY WORK OR REPAIRS MUST BE APPROVED BY THE MANUFACTURER BEFORE WORK BEGIN. ANY WORK OR REPAIRS MADE BEFORE APPROVAL MAY NOT BE COVERED UNDER WARRANTY. PLEASE NOTIFY YOUR SALES & SERVICE DEPARTMENT OF THIS POLICY.

CHAPTER

- 1) **GUIDE TO THE SIGNS**
- 2) **General summary of safety and accident-prevention instructions**
- 3) **PRODUCT IDENTIFICATION**
- 4) **DELIVERY AND ASSEMBLY**
- 5) **ADJUSTMENT, PREPARATION AND USE**
- 6) **MAINTENANCE DIRECTIONS**
- 7) **SPARE PARTS LIST**

1) GUIDE TO THE SIGNS AND SYMBOLS USED ON THE MACHINE

IMPORTANT

These signs and symbols give information to the operator on how to make the best use of the machine so as to prolong life, avoid damage, optimise work and, above all, to avoid injury to the operator and anyone within range of the machine. Note well: most of the symbols that you will find below are located on the machine, but some are only in this manual and indicate how to act or what must be done during assembly, when maintenance or repairs are being done, etc..

WARNING SIGNS

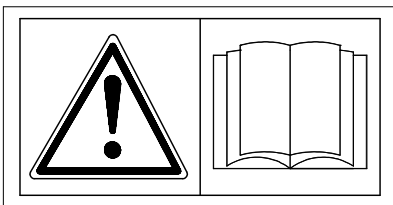

1) Before beginning operations, read the instruction manual carefully.

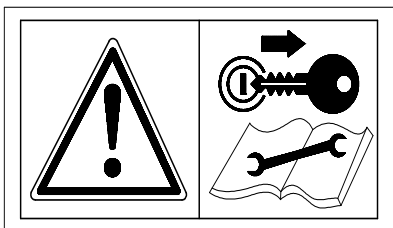

2) Before doing any maintenance or repair work, stop the machine at a suitable spot. Turn off the tractor motor, apply the brake, remove the key from the ignition and consult this manual.

DANGER SIGNS

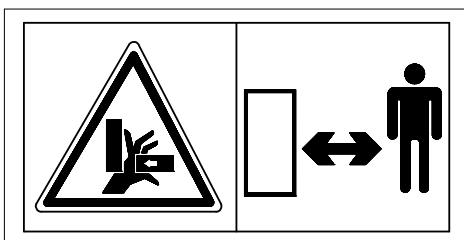

3) Warns against potential serious danger of hands being crushed.
Keep away.

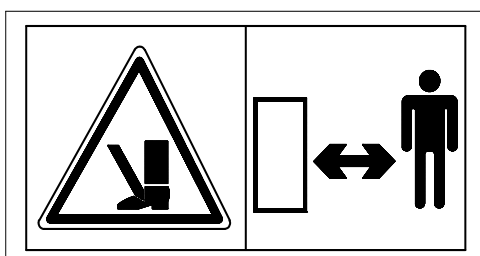

4) Warns against potential serious danger of injury to the feet.
Keep away.

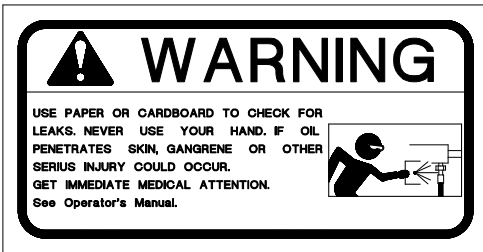

5) Use paper or cardboard to check for and/or clean any leaks from cylinders and oleo dynamic components in general. Never touch with bare hands, as it is harmful to the skin.

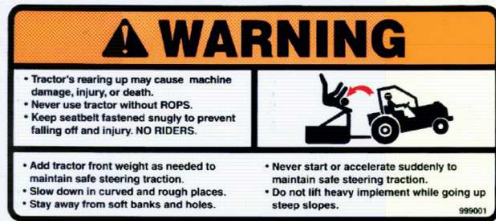

6) Warns against the potential and serious dangers to the driver and/or other persons who are near or on the machine or tractor when the tractor is used improperly and/or incautiously.

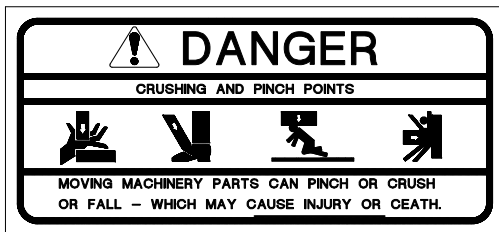

7) Summarizes all the potential and serious dangers that one risks when working improperly on the machine during assembly, use, maintenance or repair.

SYMBOLS FOR INDICATIONS AND/OR RULES

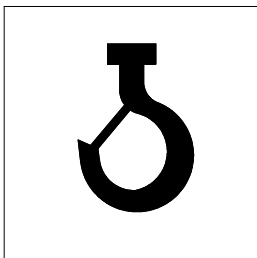

8) Indicates where a hook should be attached to the machine or to part of it if it needs to be lifted.

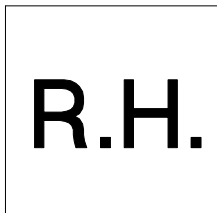

9) Indicates the components to be assembled on the right or left side of the machine. The R and L sides of the machine are usually determined by standing behind the machine and looking forward.

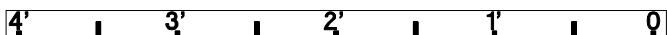
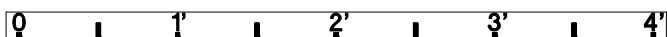

10) Indicates in feet (0'-4') the width of the machine on the right and left side.



11) Indicates the maximum speed during transport (19 MPH - 30 Km/h)

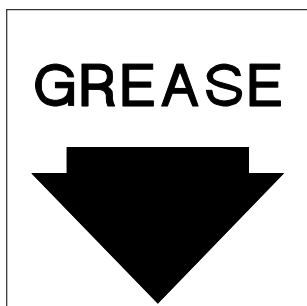

12) Indicates a greasing point.

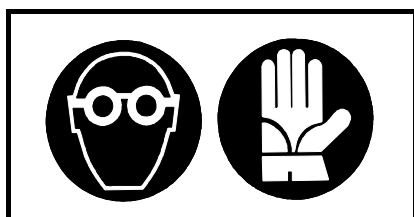

13) Recommends working with suitable clothing and/or protection during assembly, use, maintenance and repair.

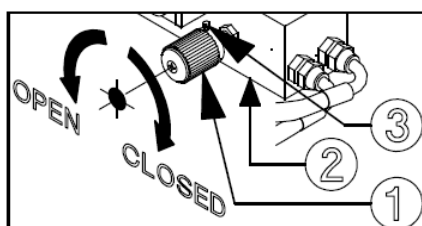

IMPORTANT NOTICE:
HANDLE 1 IN OPEN POSITION:
OPEN CIRCUIT. (Oil sent from the tractor without using any machines' cylinders flows into base 2 and goes back to tractor).
HANDLE 1 IN CLOSED POSITION:
CLOSED CIRCUIT. (Oil sent from the tractor without using any machines' cylinders does not flow into base 2 and therefore, the pressure raises in the hydraulic circuit).
 Choice open-closed depends on type of hydraulic system installed in the tractor used.
 Once selected the suitable working position lock the handle 1 with setscrew 3.
Machine is supplied with handle 1 in closed position.

14) OPEN-CLOSED CIRCUIT
 (See page 47).
 Explains how to choose the circuit to be used, depending on that installed in the tractor used.

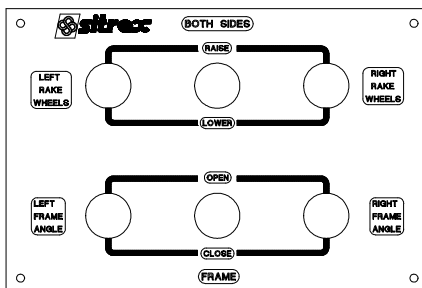

15) CONTROL BOARD
 (See pages 42,44,46,48,50,52,61,63,68,70,72).
 Explains the various operations that can be done.

Note: For the location of signs and symbols on the machine, see drawing on pg. 8-9.

2) GENERAL SUMMARY OF SAFETY AND ACCIDENT PREVENTION INSTRUCTIONS

Read all the directions carefully before using the machine. When in doubt, seek advice from the manufacturers. The manufacturing company declines all responsibility for non-compliance with the following safety and accident-prevention instructions.

- 1-** Pay attention to the danger signs and symbols in this manual and on the machine.
- 2-** Do not touch moving parts.
- 3-** All work on the machine (including adjustments) must always be carried out with the tractor immobilized and the engine switched off.
- 4-** It is strictly prohibited to carry persons or objects on the machine and/or on the tractor.
- 5-** Driving the tractor with the machine connected is absolutely forbidden to persons lacking suitable experience, or who are in poor health, or who do not have a suitable driving license.
- 6-** All accident-prevention measures recommended in this manual should be scrupulously observed.
- 7-** When a machine is attached to the tractor, always evaluate the suitability of the tractor for the purpose, in order to work safely. Keep in mind that when a machine is attached to the tractor – even if it is a towed type – it alters the tractor's stability, and therefore all the necessary precautions must be taken (ballast, tire pressure, etc.).
- 8-** Before operating the tractor and machine, check that all transport and operational safety devices are complete and working.
- 9-** When driving on public roads, you should comply with the Highway Code regulations for the country concerned.
- 10-** Before starting work, familiarize yourself with the control devices and how they work.
- 11-** Wear suitable clothes. Do not wear clothing which is loose or which could become entangled in rotating or moving parts.
- 12-** Never leave the driving seat when the tractor is running.
- 13-** It is extremely important to appreciate that road holding, steering and braking may be significantly affected with the machine attached.
- 14-** Before connecting unit, stop the engine, apply the parking brake and remove the ignition key from the instrument panel.
- 15-** Spare parts must meet the requirements as defined by the manufacturer. Use only original spare parts.
- 16-** Safety decals must always be clearly visible. They must be kept clean and replaced if they become too illegible (they can be ordered from the agent if necessary).

3) PRODUCT IDENTIFICATION

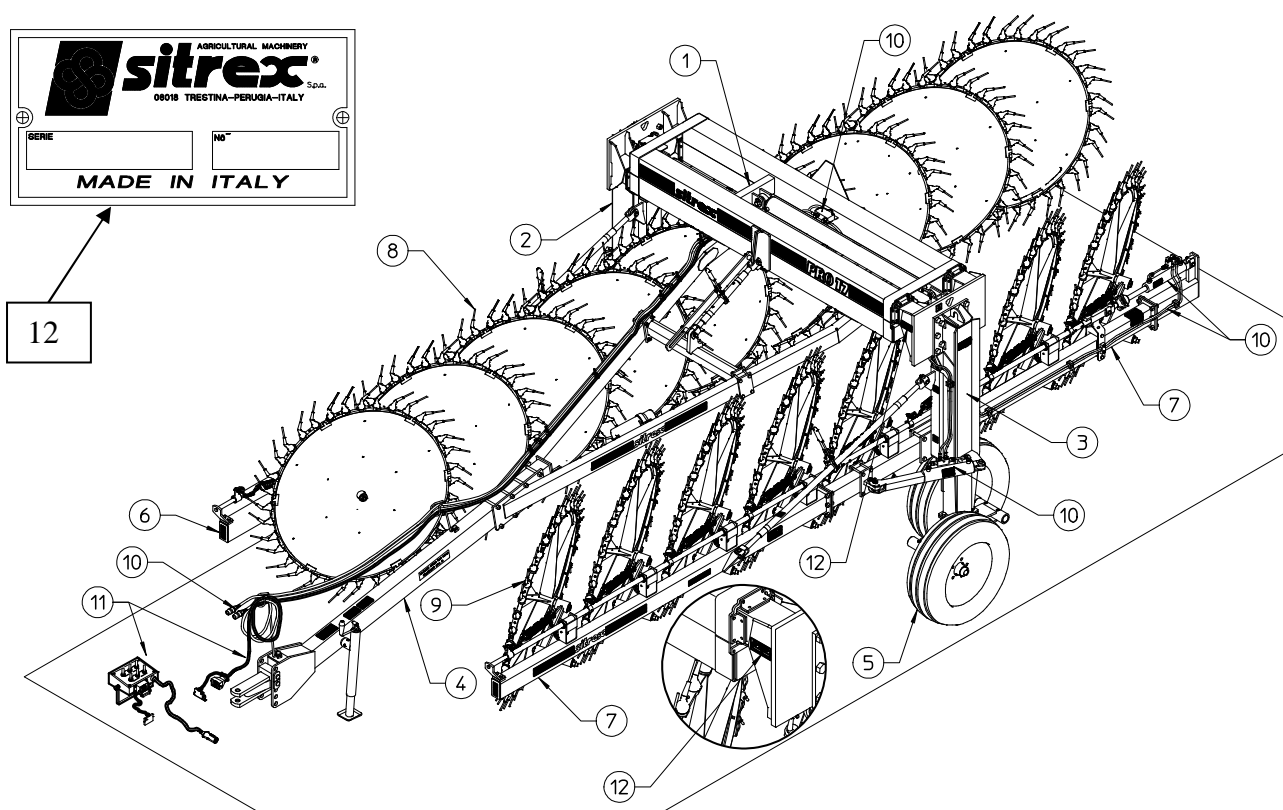

MAIN PARTS			
1	CROSSPIECES ASSEMBLY	7	LEFT SIDE SECTIONS
2	RIGHT SUPPORT	8	RIGHT RAKE WHEELS & ACCESSORIES
3	LEFT SUPPORT	9	RIGHT RAKE WHEELS & ACCESSORIES
4	DRAWBAR	10	OLEODYNAMIC COMPONENTS
5	TANDEM ASSEMBLY	11	ELECTRIC CONTROLS UNIT
6	RIGHT SIDE SECTIONS	12	IDENTIFICATION PLATE

TECHNICAL DATA

SPECIFICATIONS	PRO/17
Number of wheels	17
Wheels diameter	60"
Teeth for wheel	36
Teeth	Rubber mounted in a set of 2
Trasport width	12' 3"
Trasport leghth	28' 3"
Maximum raking width	24'
Maximum finished windrow width	72'
Rake wheel hubs	Tapered bearing
Tires	10.0/75-15,3
Minimum power required	80 HP - 60 KW
Weight	2800 kg - 6170 lbs

All data are indicative. Sitrex reserves the right to change them without advance notice.

LOCATION OF LABELS AND DEVICES FOR SAFETY, FOR CONTROLS AND FOR IDENTIFICATION OF THE MACHINE AND THE MANUFACTURER.

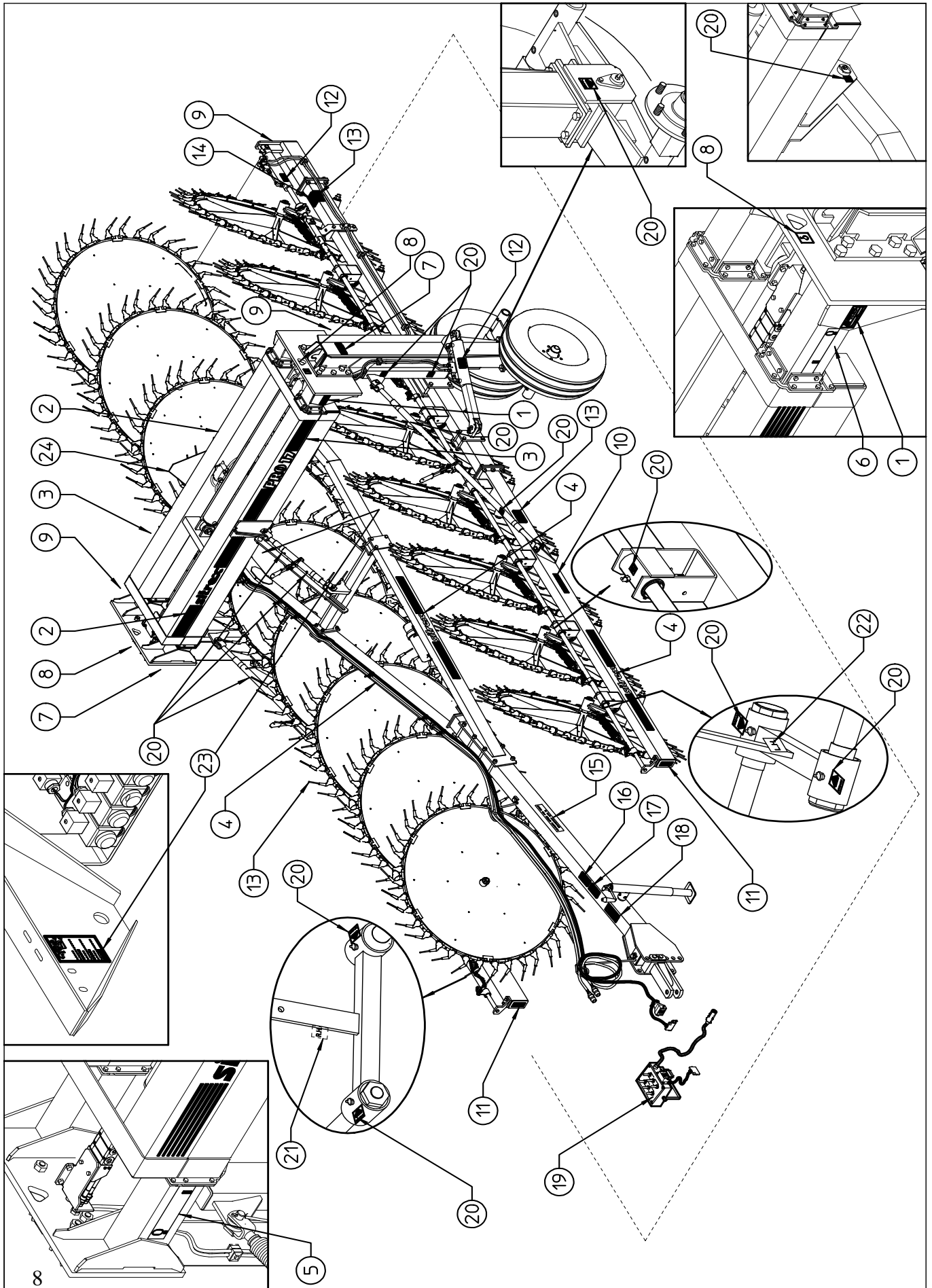

LOCATION OF LABELS AND DEVICES FOR SAFETY, FOR CONTROLS AND FOR IDENTIFICATION OF THE MACHINE AND THE MANUFACTURER

1	IDENTIFICATION PLATE	1	*
2	LARGE SITREX LOGO	2	*
3	"PRO 17" STICKER	2	*
4	SMALL SITREX LOGO	4	*
5	RH EXTENSION MEASUREMENT STICKER	1	See pg.4 (point 10)
6	LH EXTENSION MEASUREMENT STICKER	1	See pg.4 (point 10)
7	"DANGER" STICKER	2	See pg.4 (point 7)
8	"LIFTING HOOK" STICKER	2	See pg.4 (point 10)
9	RED REFLEX REFLECTOR	4	*
10	YELLOW REFLEX REFLECTOR	2	*
11	SMALL YELLOW REFLEX REFLECTOR	2	*
12	"WARNING....." STICKER	9	See pg.4 (point 5)
13	"DANGER FOR FEET" STICKER	10	See pg.3 (point 4)
14	"DANGER OF CRUSHING HANDS" STICKER	11	See pg.3 (point 3)
15	"MAXIMUM SPEED" STICKER	2	See pg.3 (point 11)
16	"OPERATOR'S MANUAL" STICKER	1	See pg.3 (point 1)
17	"OPERATOR'S MANUAL" STICKER	1	See pg.3 (point 2)
18	"WARNING....." STICKER	1	See pg.4 (point 6)
19	CONTROLS STICKER	1	See pg.4 (point 15)
20	"GREASE POINT" STICKER	65	See pg.5 (point 12)
21	"R.H." SIDE STICKER	9	See pg.4 (point 9)
22	"L.H." SIDE STICKER	8	See pg.4 (point 9)
23	"OPEN-CLOSED CIRCUIT" STICKER	1	See pg.4 (point 14)
24	REFLEX REFLECTOR TRIANGLE	1	*

4) DELIVERY AND ASSEMBLY

CHECKING THE MACHINE ON DELIVERY

All parts are carefully checked before dispatch or delivery.

On receiving the machine, ensure that it not been damaged during transport. If damage has occurred, contact the dealer concerned.

Note well: the packing consists of wood, plastic film, cardboard and steel supports, and must be disposed of according to the laws in force in your area.

Handle the crates and pallets received using power lifts suitable for lifting the weights given. Crate B contains the crosspieces assembly 1 and is the heaviest. To correctly handle the pallet with the rake wheels the forks of the forklift 2 must go all the way through and out the opposite side of the pallet.

In order to unpack the rake wheels, screws 3 must be removed.

Each machine arrives packed in two crates and one pallet

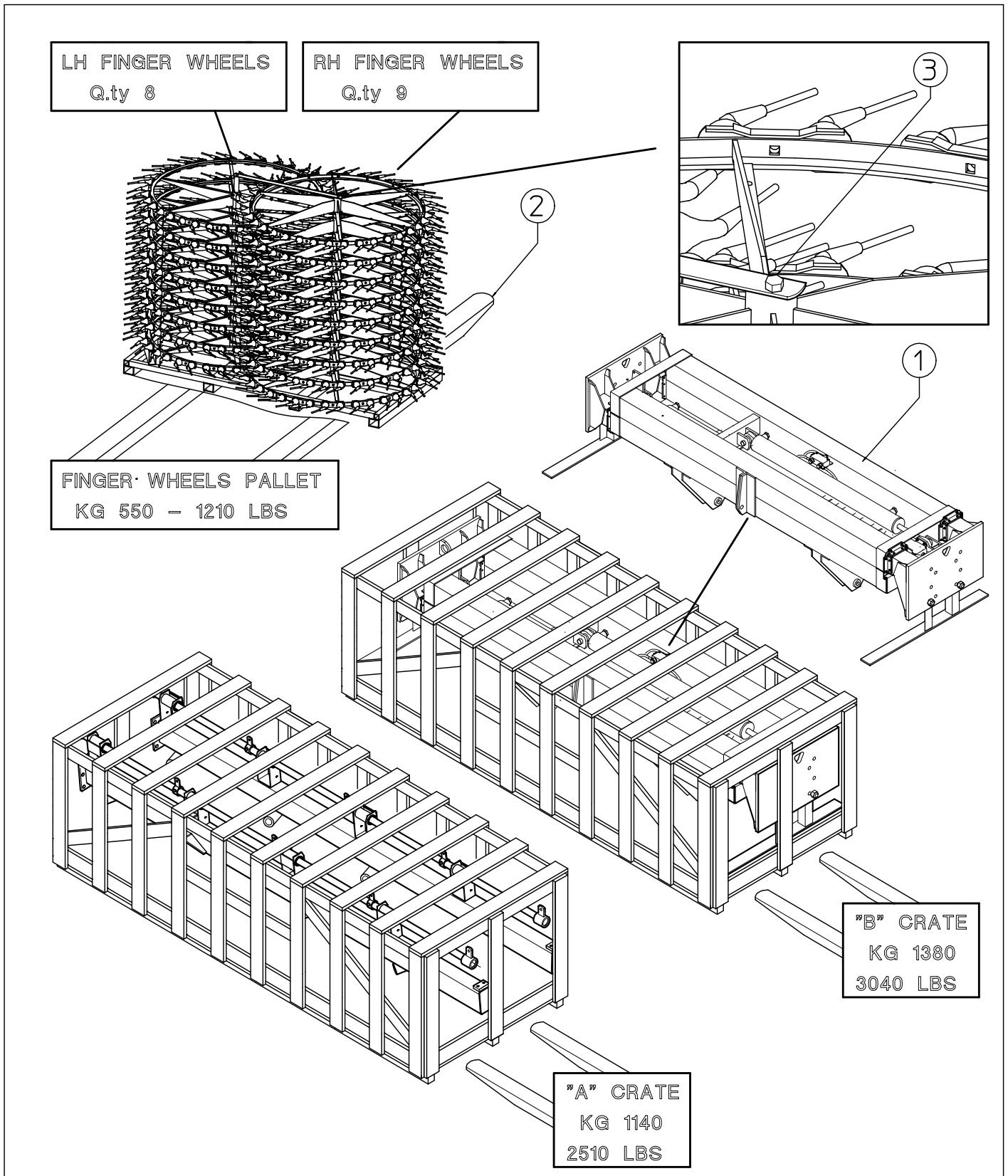

Assembly instructions

Examples of general measurements for identifying the assembly accessories based on type.

To make it easier to identify the assembly accessories (bolts, nuts, washers, pins, etc.) according to the general dimensions and the type, we provide a diagram that shows you the accessory parts to which the measurements refer in the various steps of the assembly.

The illustrations are schematic and do not faithfully represent the accessories, but they are nonetheless an aid in identifying them correctly.

Note well: the accurate measurements are those given in mm; those given in inches are rounded off and therefore as regards the thread sizes the figure in inches is given only as an aid, as they do not accurately describe the thread.

You can see the following examples:

Box “A”: shows the springs that are identified with the diameter of the wire, the outside diameter and the length, thus in this case $\varnothing 3\text{-}\varnothing 18 \times 110$ ($\varnothing 0.12\text{''-}\varnothing 0.71\text{''} \times 4.33\text{''}$)

Box “B”: shows the handles, spring pins, split pins, etc. that are identified with the diameter of the shaft and the length, thus in this case $\varnothing 8 \times 50$ ($\varnothing 0.12\text{''} \times 1.97\text{''}$)

Box “C”: shows the shims, bushings, spacers and washers in general that are identified with the inside diameter, outside diameter and length and/or thickness (for washers), thus in this case $\varnothing 18\text{-}\varnothing 35 \times 30$ ($\varnothing 0.71\text{''-}\varnothing 1.38\text{''} \times 1.18\text{''}$) or for the washers $\varnothing 18\text{-}\varnothing 35 \times 3$ ($\varnothing 0.71\text{''-}\varnothing 1.38\text{''} \times 0.12\text{''}$).

Box “D”: shows the pins, bolts, etc. that are identified with the outside diameter (thread diameter for bolts) and length, thus in this case $\varnothing 20 \times 70$ ($\varnothing 0.78\text{''} \times 2.76\text{''}$) or for the bolts M20 x 70 (0.78'' x 2.76'').

Box “E”: shows the nuts and grease nipples that are identified with the thread diameter, thus in this case M10 (0.39'').

Box “F”: shows the R-clips that are identified with the wire diameter, thus in this case $\varnothing 3$ ($\varnothing 0.12\text{''}$).

Assembly instructions

Examples of general measurements for identifying the assembly accessories based on type.

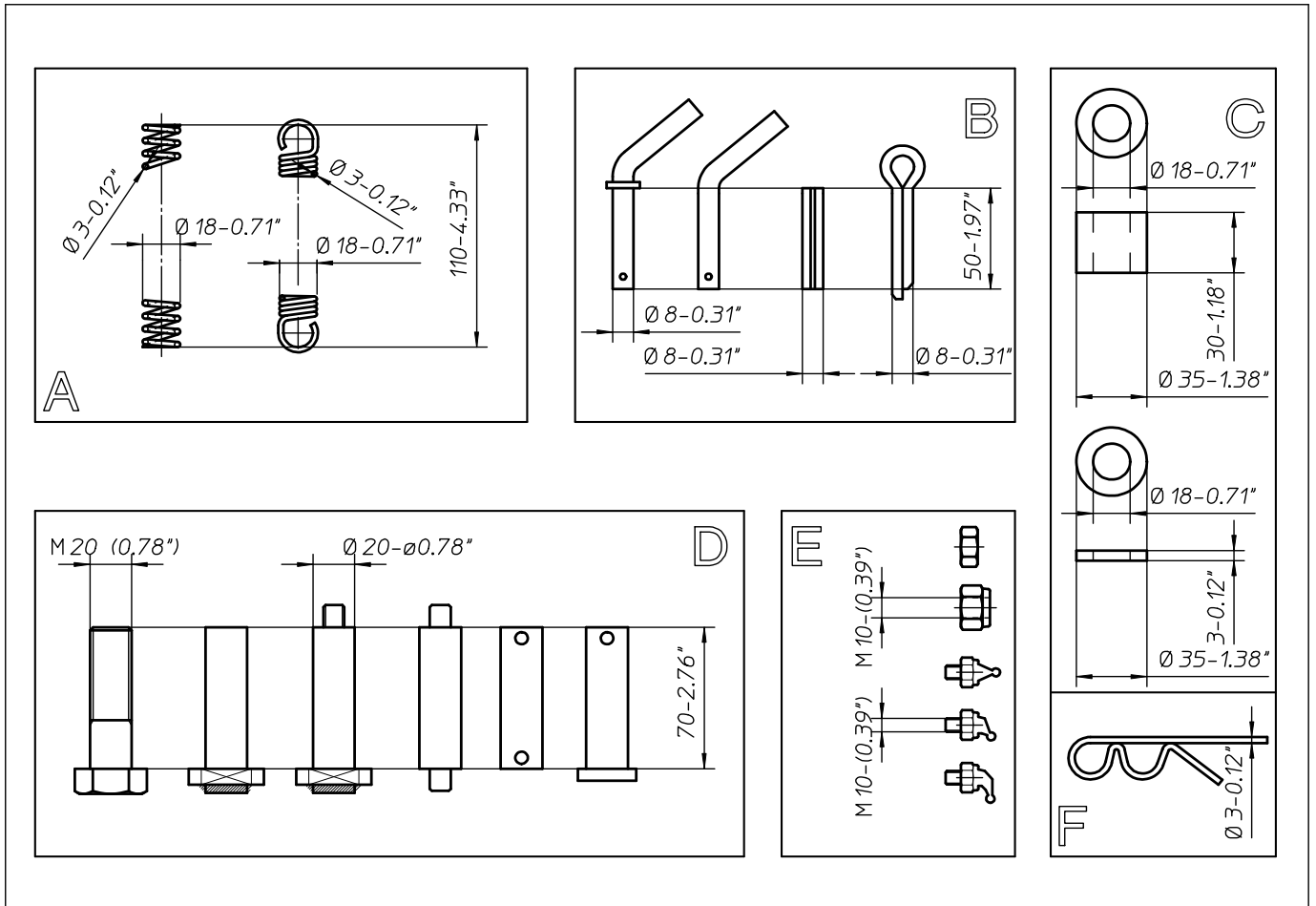

When tightening the bolts refer to the tightening torque table (the class of the material is generally stamped on the head of the bolts).

MINIMUM HARDWARE TIGHTENING TORQUES

IN NEWTON-METERS (FOOT POUNDS) FOR NORMAL ASSEMBLY APPLICATIONS

METRIC NON-FLANGED HARDWARE AND LOCKNUTS

NOMINAL SIZE	CLASS 5.8		CLASS 8.8		CLASS 10.9		LOCKNUT CL.8 W/CL.8 BOLT
	UNPLATED	PLATED W/ZnCr	UNPLATED	PLATED W/ZnCr	UNPLATED	PLATED W/ZnCr	
M4	1.7 (15)*	2.2 (19)*	2.6 (23)*	3.4 (30)*	3.7 (33)*	4.8 (42)*	2.3 (20)*
M6	5.8 (51)*	7.6 (67)*	8.9 (79)*	12 (102)*	13 (115)*	17 (150)*	7.8 (69)*
M8	14 (124)*	18 (159)*	22 (195)*	28 (248)*	31 (274)*	40 (354)*	19 (169)*
M10	28 (21)	36 (27)	43 (32)	56 (41)	61 (45)	79 (58)	38 (28)
M12	49 (36)	63 (46)	75 (55)	97 (72)	107 (79)	138 (102)	66 (49)
M16	121 (89)	158 (117)	186 (137)	240 (177)	266 (196)	344 (254)	164 (121)
M20	237 (175)	307 (226)	375 (277)	485 (358)	519 (383)	671 (495)	330 (243)
M24	411 (303)	531 (392)	648 (478)	839 (619)	897 (662)	1160 (855)	572 (422)

NOTE: Torque values shown with * are inch pounds.

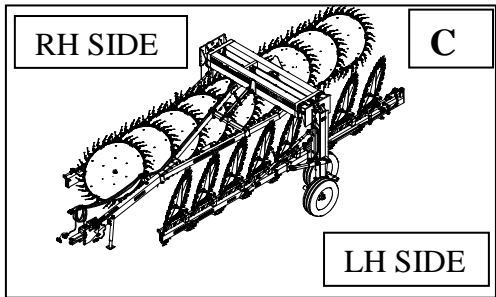

Point 1

KG 800
1760 LBS

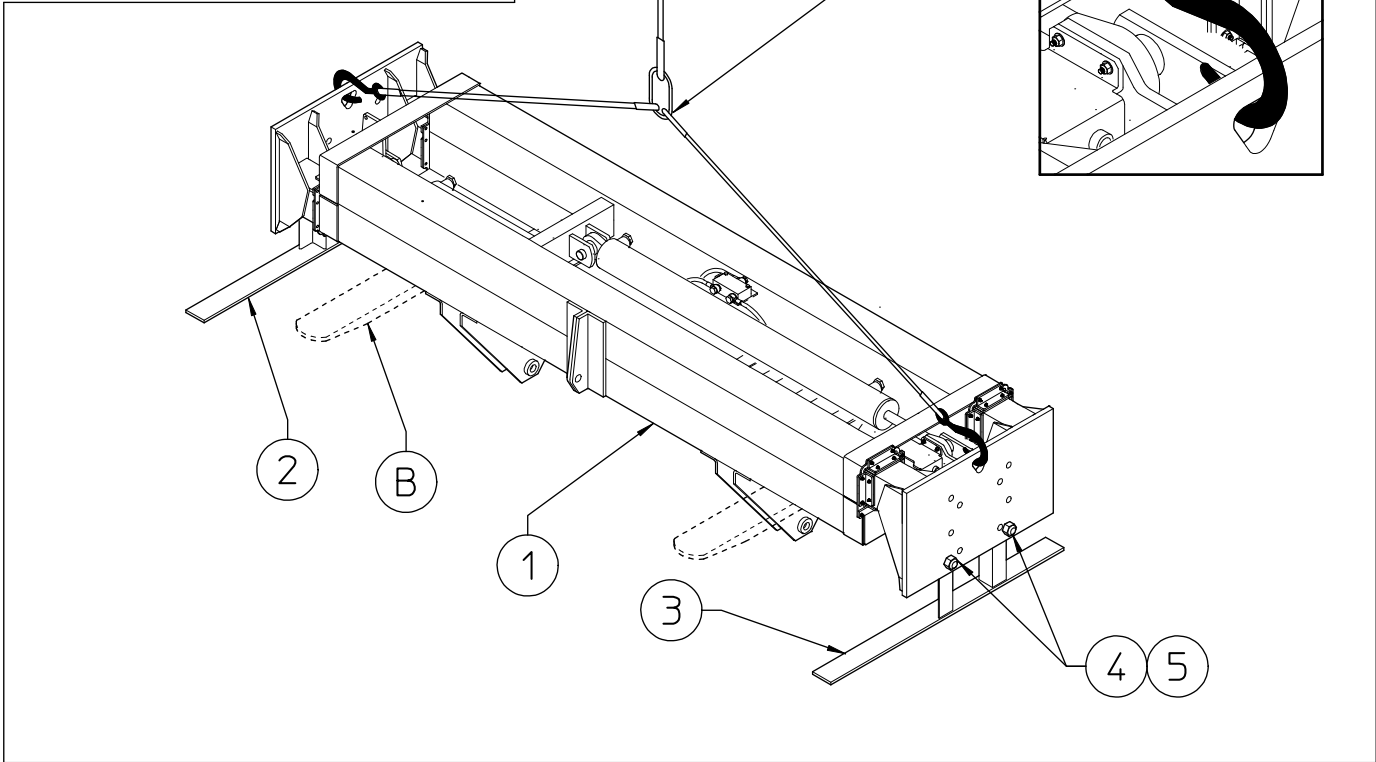
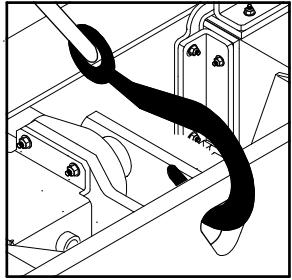

Point 2

KG 1110
2440 LBS

KG 155
340 LBS

KG 155
340 LBS

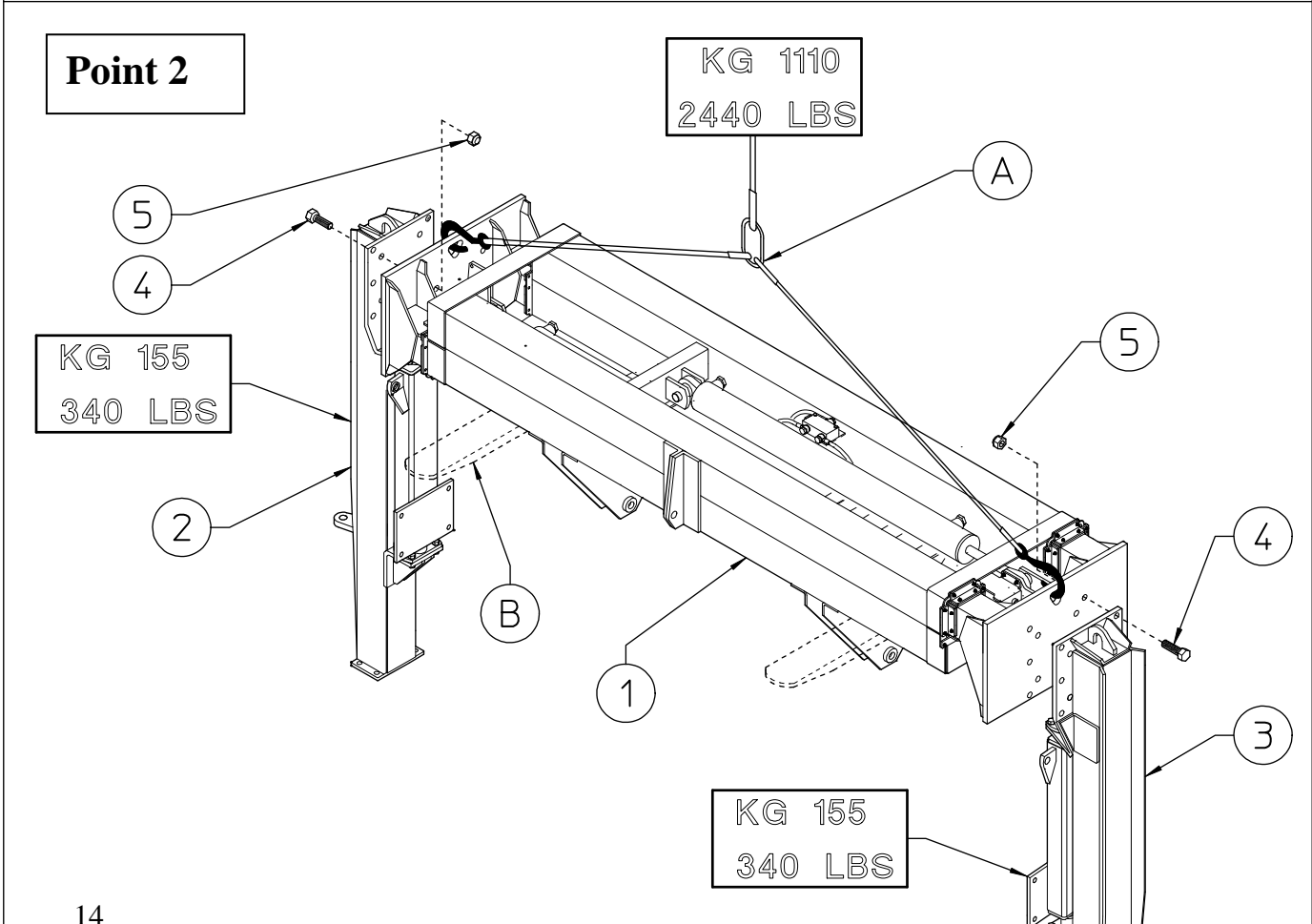

Assembly Sequence

Note: In the description of the assembly sequence the terms “right” and “left” will be used in reference to the sides of the machine. “Right” and “left” are conventionally assigned looking at the machine from the rear (see box “C”).

As already mentioned in the recommendations in the assembly instructions chapter, much care and caution as well as the proper tools and a suitable area must be used during these operations. Keep in mind that up until stage 3 the components to be assembled are heavy and unstable and therefore potentially dangerous for the persons in charge of handling. Note: the weights given for the various components are to be considered as having a tolerance of +/- 5%, as they depend on the tolerances of the original materials. Remember that the weight refers to the quantity of one piece. The weight given for the lifting cable includes the parts assembled in that stage. Only weights of a significant amount are shown (over 15 kg-35lbs).

Point 1 (DANGER)

Remove the rear crosspieces assembly 1 from the packing using a type A or B lift suitable for the weight to be lifted (800 kg – 1760 lbs). Keep in mind that the parts to be attached during the assembly stage done with the aid of the lift will increase the weight to be supported from the present 800 kg – 1760 lbs to the 1310 kg – 2885 lbs of assembly stage 3, after which the lift will be needed to keep the assembled parts in balance. Therefore it is recommended that a lift be used that is suitable for the weight that will be reached in stage 3.

Remove the packing supports 2-3 by unscrewing nuts 4 and bolts 5. Supports 2-3 and nuts 4 and bolts 5 are not to be used for assembly.

Point 2 (DANGER)

Note: the electric cables, solenoid valve assembly and hoses have already been connected to assembly 1, therefore be careful not to damage these parts during handling and assembly.

Attach supports 2-3 (RH and LH) to the rear crosspieces assembly 1 using bolts 4 and nuts 5.

In this step, you will use:

Item 4: 20 bolts M20x60 (0.78” x 2.36”)

Item 5: 20 nuts M20 (0.78”)

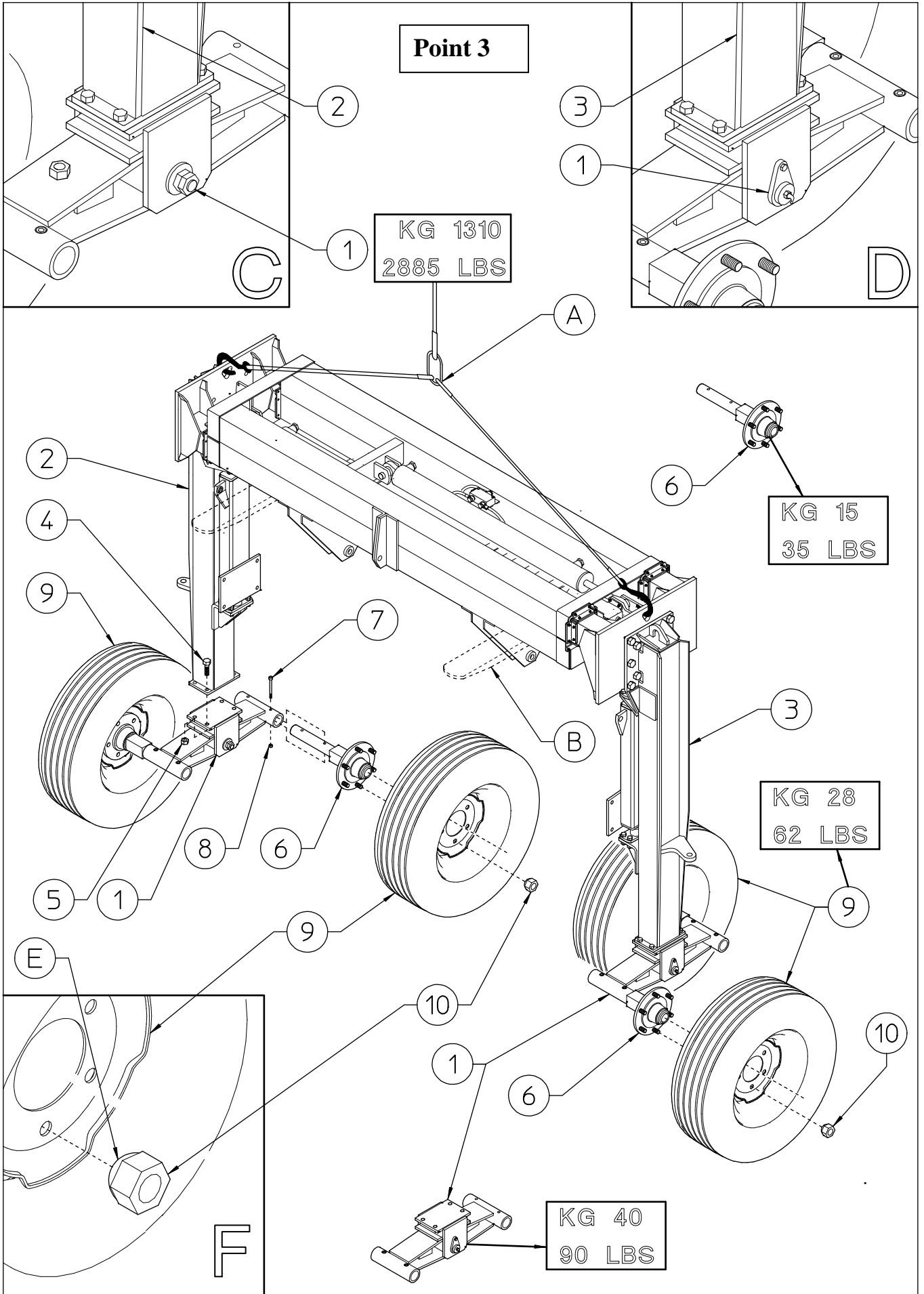

Point 3 (DANGER)

Keep the parts already assembled adequately raised using the lift A or B. Attach supports 1 to supports 2-3 (RH and LH) using bolts 4 and nuts 5. Support 1 attached to support 2 must appear as shown in box “C”, and support 1 attached to support 3 must appear as shown in box “D”. Assemble hubs 6 to supports 1 using bolts 7 and nuts 8. Attach the wheels 9 to the hubs 6 using nuts 10. Note: the rounded part “E” of nut 10 must face the rim of wheel 9 as shown in box “F”.

In this step, you will use:

- Item 4: 8 bolts M16x45 (0.63” x 1.77”)
- Item 5: 8 nuts M16 (0.63”)
- Item 7: 8 bolts M10x70 (0.39” x 2.75”)
- Item 5: 8 nuts M10 (0.39”)
- Item 10: 24 nuts M18x1.5 (0.71” x 0.06”)

Point 4

KG 1430
3150 LBS

KG 60
135 LBS

KG 60
135 LBS

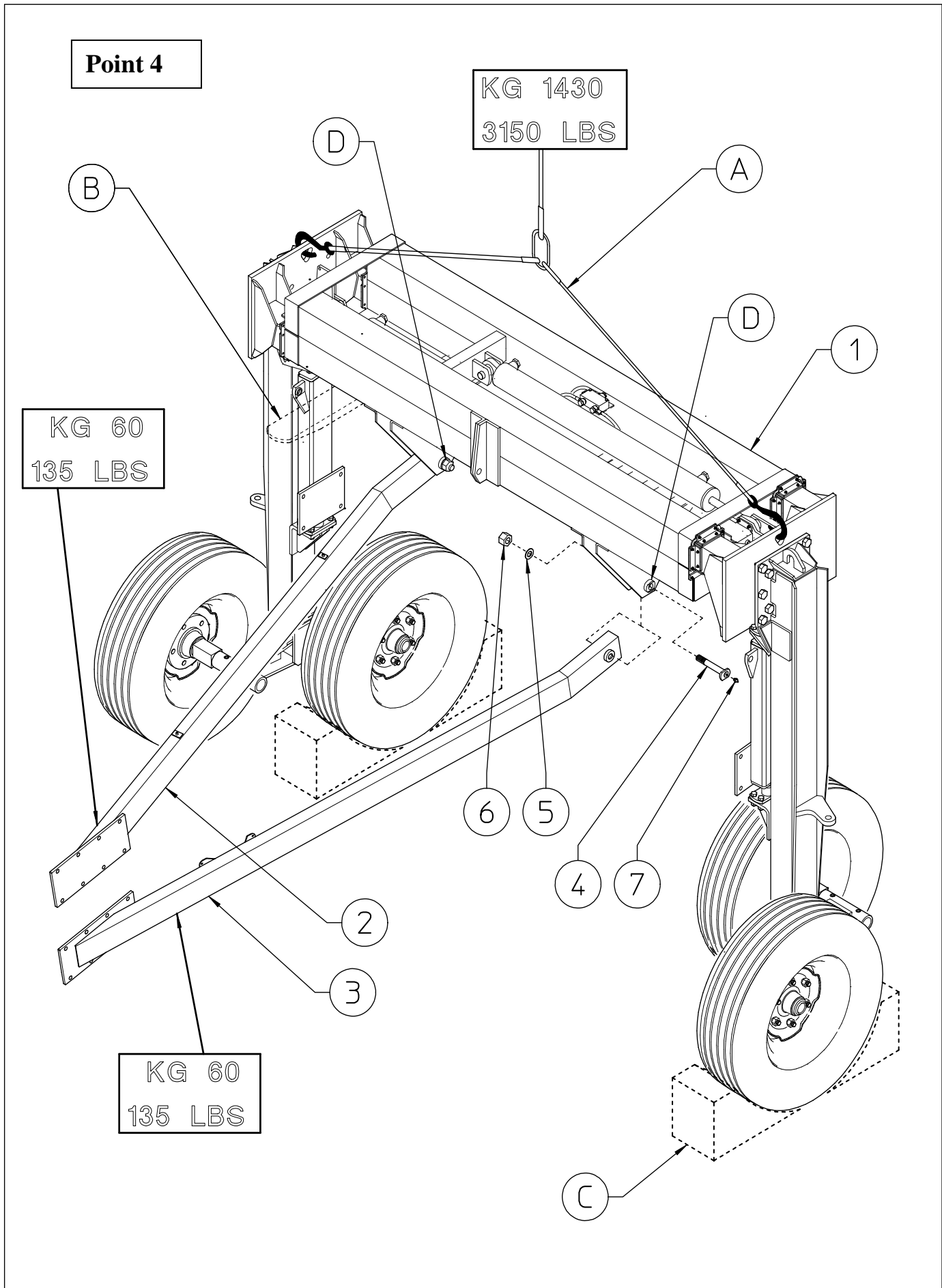

Point 4 (DANGER)

Keep the parts already assembled adequately balanced using the lift A or B.

To improve the stability of the parts assembled, chock the wheels with chocks “C”.

Note: from this point on the parts to be added no longer weigh directly on the lift, which now serves mainly to keep assembly 1 balanced, as it rests on the ground with the wheels. If you wish to keep assembly 1 raised above the ground to facilitate assembly or for other reasons, you must consider the weight that will be added bit by bit so as not to exceed the limits of the lift. Attach drawbars 2-3 (RH and LH) to points “D” on the crosspiece assembly 1 using the pins 4, washers 5 and nuts 6. Attach the grease nipples 7 to the pins 4.

In this step, you will use:

- Item 4: 2 pins $\varnothing 30 \times 134$ (1.18” x 5.27”)
- Item 5: 2 washers $\varnothing 25$ (1”)
- Item 6: 2 nuts M24 (0.94”)
- Item 7: 2 grease nipples M8 (0.31”)

Point 5

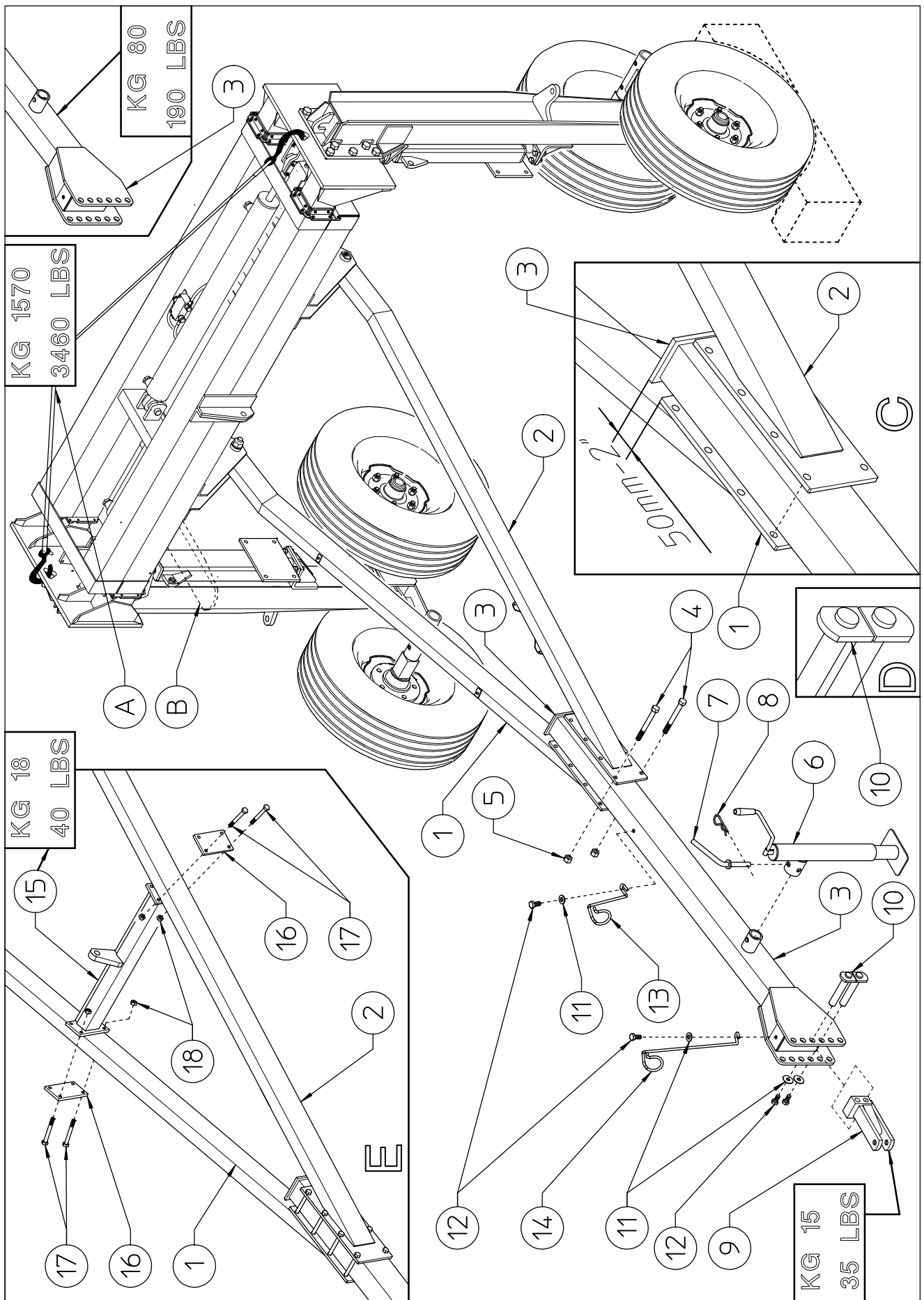

Point 5 (DANGER)

Keep the parts already assembled adequately balanced using the lift A or B.

Attach the front drawbar 3 between drawbars 1-2 (RH and LH) at the measure of about 50 mm – 2” using bolts 4 and nuts 5 (see box “C”). This measure allows normal operation but it can be adapted for the various needs of the user depending on the type of tractor used, the land to be worked, etc.

Attach the parking stand 6 to the drawbar 3 using pin 7 and pin 8. Attach the tractor hitch 9 to drawbar 3 using pins 10, washers 11 and screws 12. Pins 10 must be placed as shown in box “D”. Attach the hose brackets 13-14 to their respective positions on the drawbar 3 using washers 11 and screws 12. Attach the drawbar crosspiece 15 (see box “E”) to drawbars 1-2 (RH and LH) using the counterplates 16, bolts 17 and nuts 18.

In this step, you will use:

- Item 4: 8 bolts M16x145 (0.63” x 5.71”)
- Item 5: 8 nuts M16 (0.63”)
- Item 7: 1 pin \varnothing 15x78 (0.59” x 3.07”)
- Item 8: 1 pin \varnothing 3 (0.12”)
- Item 10: 2 pins \varnothing 25x125 (1” x 5”)
- Item 11: 4 washers \varnothing 12-40 x 4 (\varnothing 0.47” – 1.57” x 0.16”)
- Item 12: 4 screws M12 x 25 (0.47” x 1”)
- Item 17: 8 bolts M12x100 (0.47” x 4”)
- Item 18: 8 nuts M12 (0.47”)

Point 6

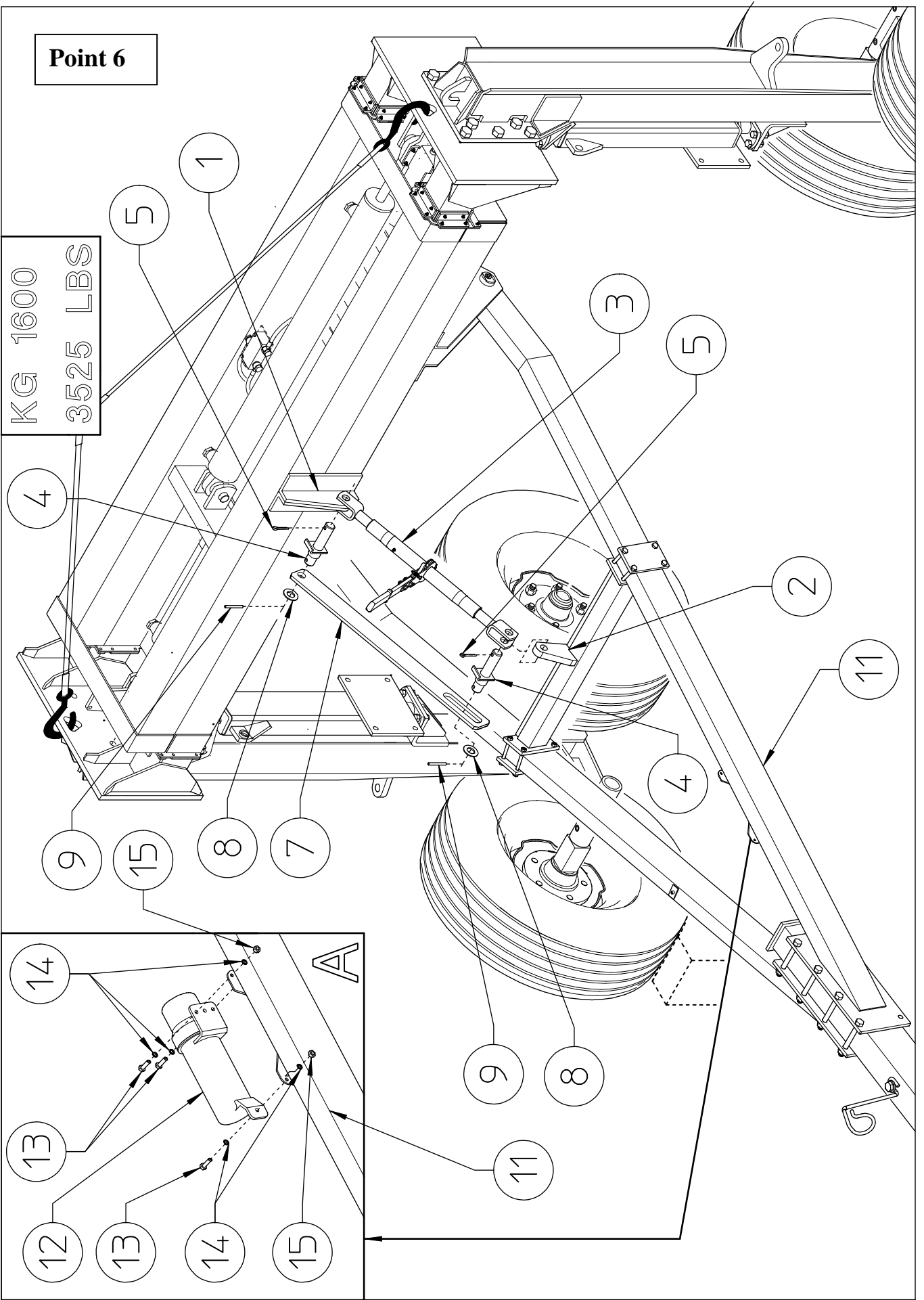

Point 6 (DANGER)

The assembly done so far gives the machine good stability; however, proceed with caution.

Attach the ratchet link 3 to the bracket 1 on the crosspieces assembly and to bracket 2 on the drawbar crosspiece using pins 4 and split pins 5. Attach the safety arm 7 to the free ends of pins 4 and fasten with the washers 8 and spring pins 9. Attach the manual canister 12 to the drawbar at point 11 (see box "A") using bolts 13, washers 14 and nuts 15. Note: all manuals and other documents regarding the machine must be placed in the manual canister 12 so that they may be consulted at any time.

In this step, you will use:

- Item 4: 2 pins $\varnothing 25\text{-}\varnothing 30 \times 134$ ($\varnothing 1'' - \varnothing 1.18'' \times 5.27''$)
- Item 5: 2 split pins $\varnothing 6 \times 35$ ($0.24'' \times 1.38''$)
- Item 8: 2 washers $\varnothing 25$ (1'')
- Item 9: 2 spring pins $\varnothing 8 \times 40$ ($0.31'' \times 1.57''$)
- Item 13: 3 bolts M6x20 ($0.24'' \times 0.79''$)
- Item 14: 6 washers $\varnothing 6.6\text{-}18 \times 2$ ($\varnothing 0.26'' - 0.71'' \times 0.08''$)
- Item 15: 3 nuts M6 ($0.24''$)

Point 7

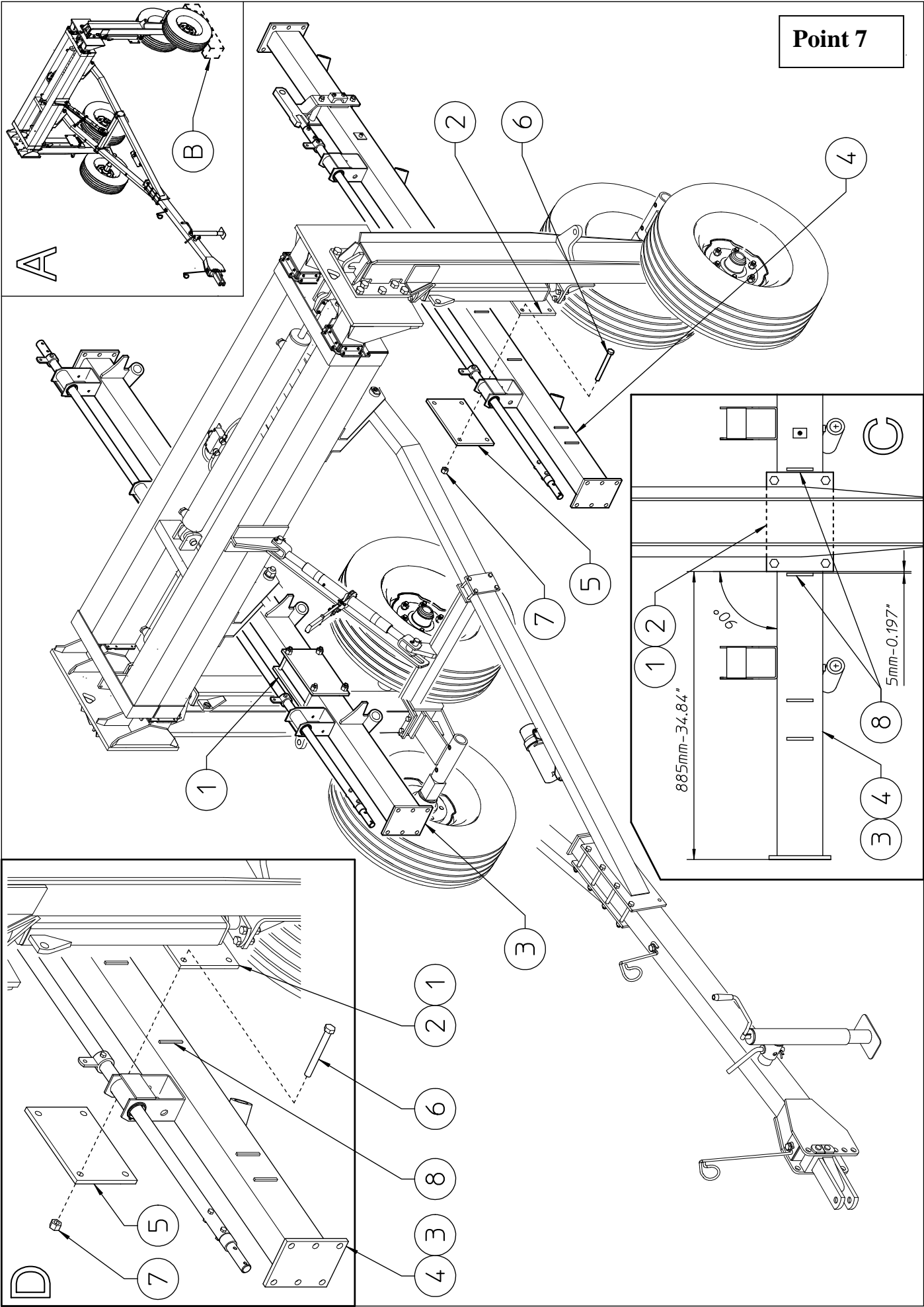

Point 7 (ATTENTION)

The assembly done so far (see box “A”) gives the machine full stability, therefore the lifts can be removed. Do not remove chocks “B” from the wheels. Continue assembly using maximum caution.

Attach the sections 3-4 (RH and LH) to the supports 1-2 using the counterplates 5, bolts 6 and nuts 7. The support plates 1-2 must be placed between the reference plates 8 (see boxes “C” and “D”) of sections 3-4 and the free space between plates 8 must be the same on each side (5 mm-0.197”, see box “C”); sections 3-4 (RH and LH) must be horizontal to the ground (at 90° in relation to the support plates 1-2, see box “C”).

In this step, you will use:

Item 6: 8 bolts M16x130 (0.63” x 5.12”)

Item 7: 8 nuts M16 (0.63”)

Point 8

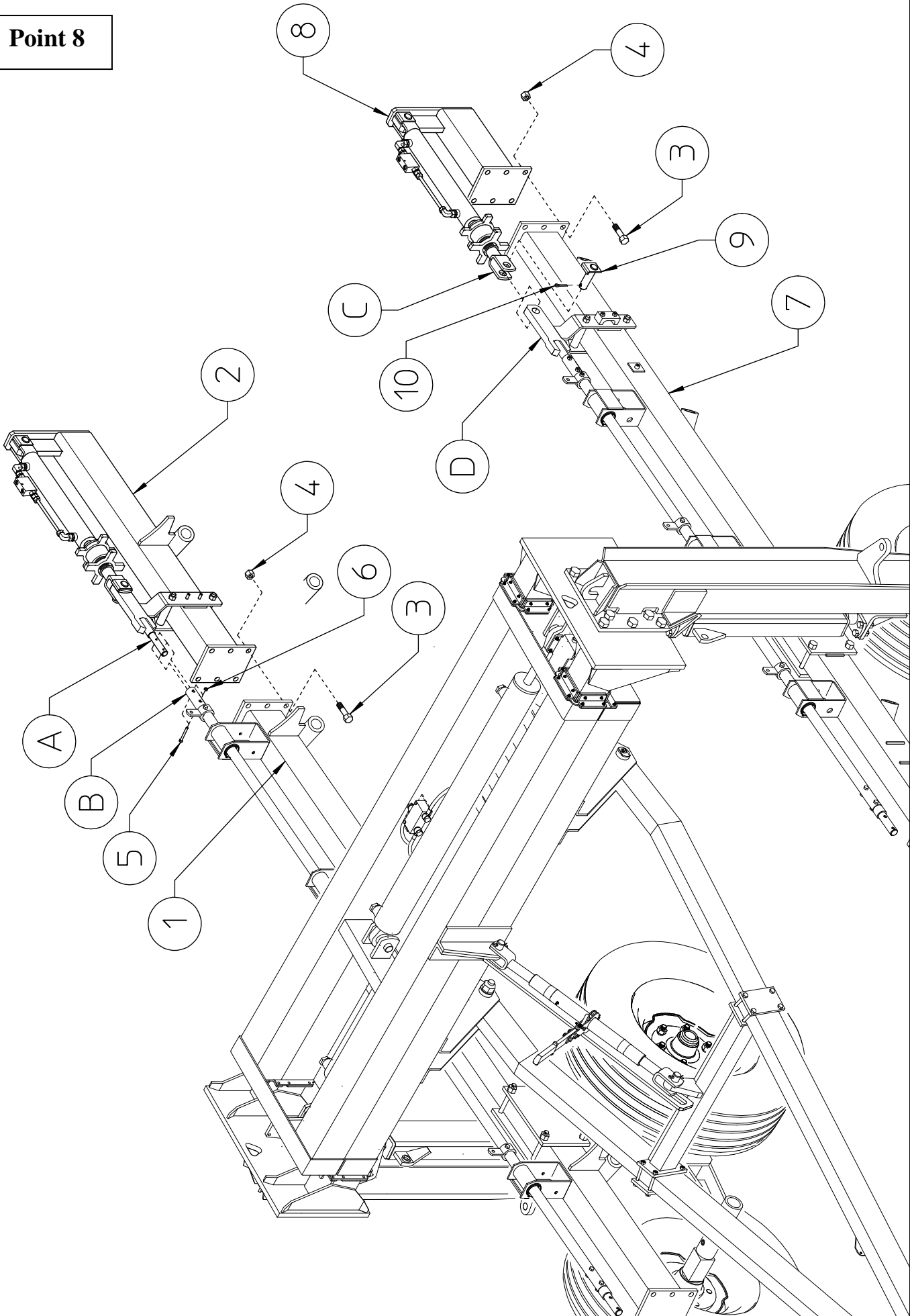

Point 8 (ATTENTION)

Continue assembly using maximum caution.

Note: in some cases, for packing necessities or to facilitate assembly, screws, bolts, washers, nuts and accessories have been preassembled by the manufacturer, and therefore they must be removed in order to carry out the assembly. The parts not preassembled are found in the nuts & bolts bag and/or in the assembly boxes. This note holds true also for the following stages.

Attach the support with the cylinder and accessories 2 to the RH section 1 using bolts 3 and nuts 4. Fasten pin “A” of support 2 to the tube “B” on section 1 using bolts 5 and nuts 6. Attach the support with the cylinder and accessories 8 to the LH section 7 using bolts 3 and nuts 4. Fasten connector “C” on the cylinder of support 8 to the connector “D” on section 7 using the pin 9 and the split pin 10.

In this step, you will use:

- Item 3: 8 bolts M16x45 (0.63” x 1.77”)
- Item 4: 8 nuts M16 (0.63”)
- Item 5: 2 bolts M8x45 (0.31” x 1.77”)
- Item 6: 2 nuts M8 (0.31”)
- Item 9: 1 pin \varnothing 25x50 (\varnothing 1“ x 2”)
- Item 10: 2 split pins \varnothing 6x35 (0.24” x 1.38”)

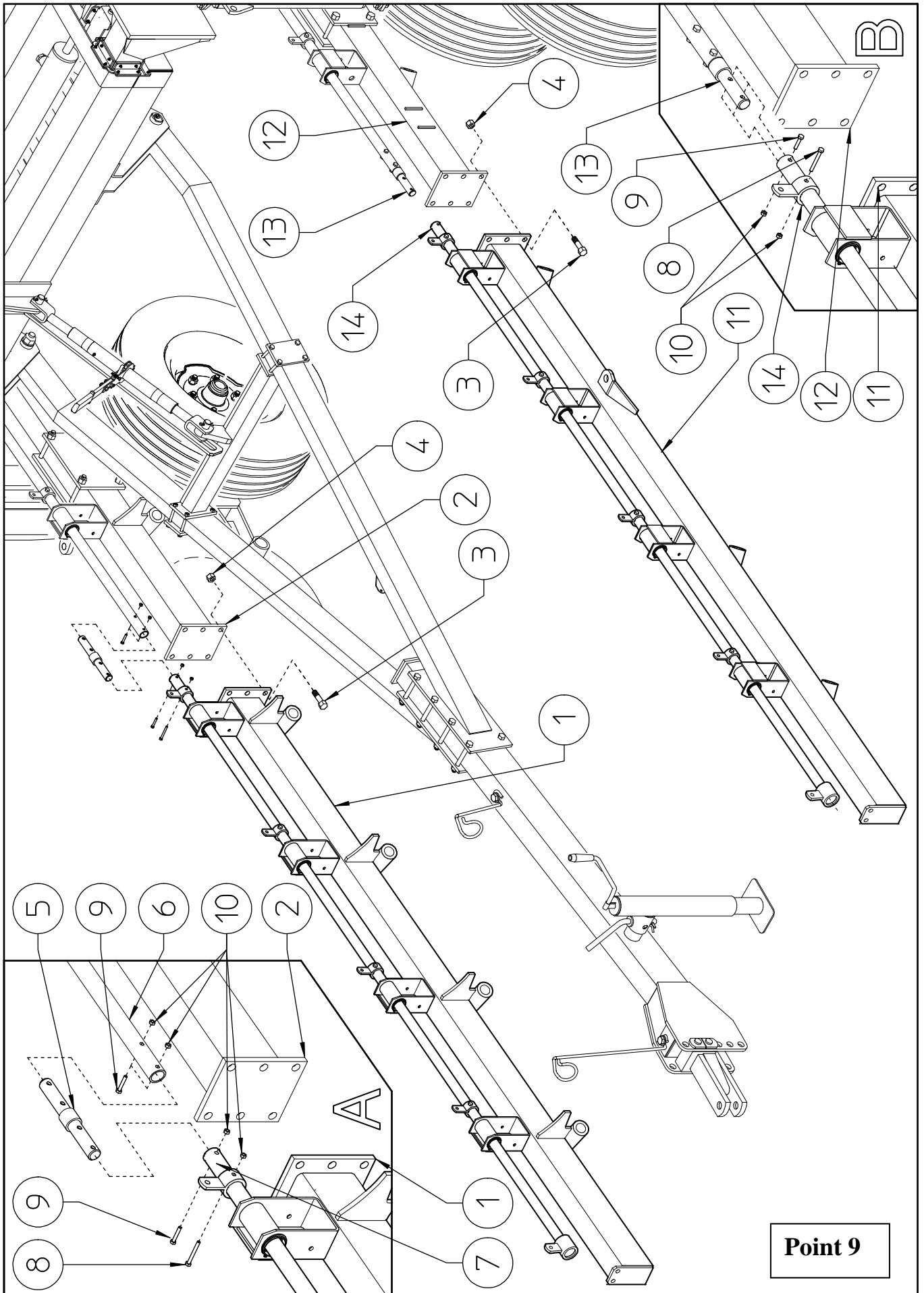

Point 9 (ATTENTION)

Continue assembly using maximum caution.

Attach RH section 1 to RH section 2 using bolts 3 and nuts 4. Connect tube 6 on section 2 to tube 7 on section 1 by means of pin 5 (see box “A”) using bolts 8-9 and nuts 10. Attach LH section 11 to LH section 12 using bolts 3 and nuts 4. Connect pin 13 (see box “B”) of section 12 to tube 14 of section 11 using bolts 8-9 and nuts 10.

In this step, you will use:

Item 3: 8 bolts M16x45 (0.63” x 1.77”)

Item 4: 8 nuts M16 (0.63”)

Item 8: 2 bolts M8x60 (0.31” x ”)

Item 9: 4 bolts M8x45 (0.31” x 1.77”)

Item 10: 6 nuts M8 (0.31”)

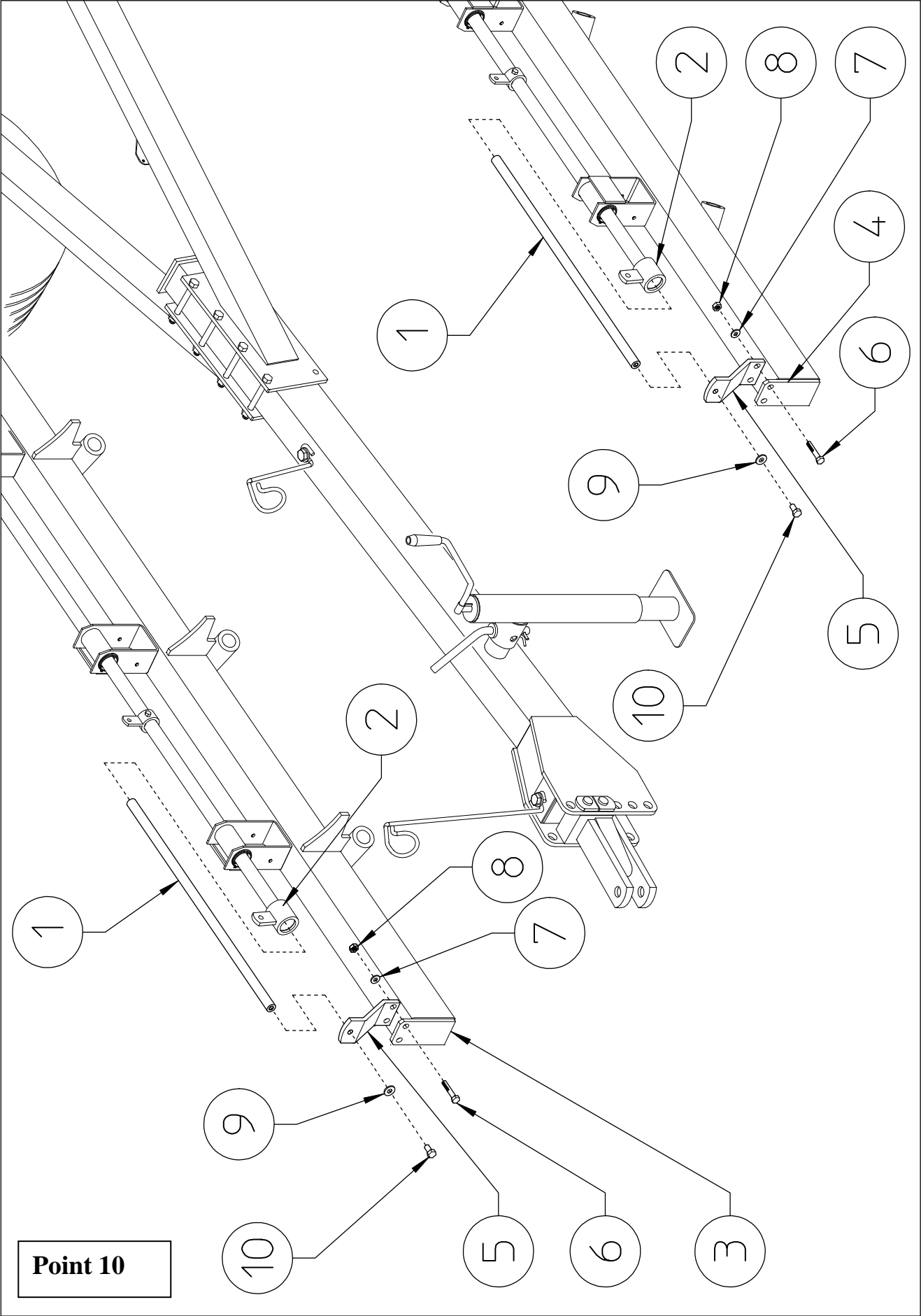

Point 10 (ATTENTION)

Continue assembly using maximum caution.

Insert pins 1 into opening 2 in the tubes on sections 3-4 (RH and LH). Attach brackets 5 to the ends of sections 3-4 using screws 6, washers 7 and nuts 8. Join pins 1 to brackets 5 using the washers 9 and screws 10.

In this step, you will use:

- Item 6: 4 screws M10x35 (0.39" x 1.38")
- Item 7: 4 washers ϕ 10.5 (0.41")
- Item 8: 4 nuts M10 (0.39")
- Item 9: 4 spring washers ϕ 10.5 (0.41")
- Item 10: 4 screws M12x20 (0.47" x 0.79")

Point 11

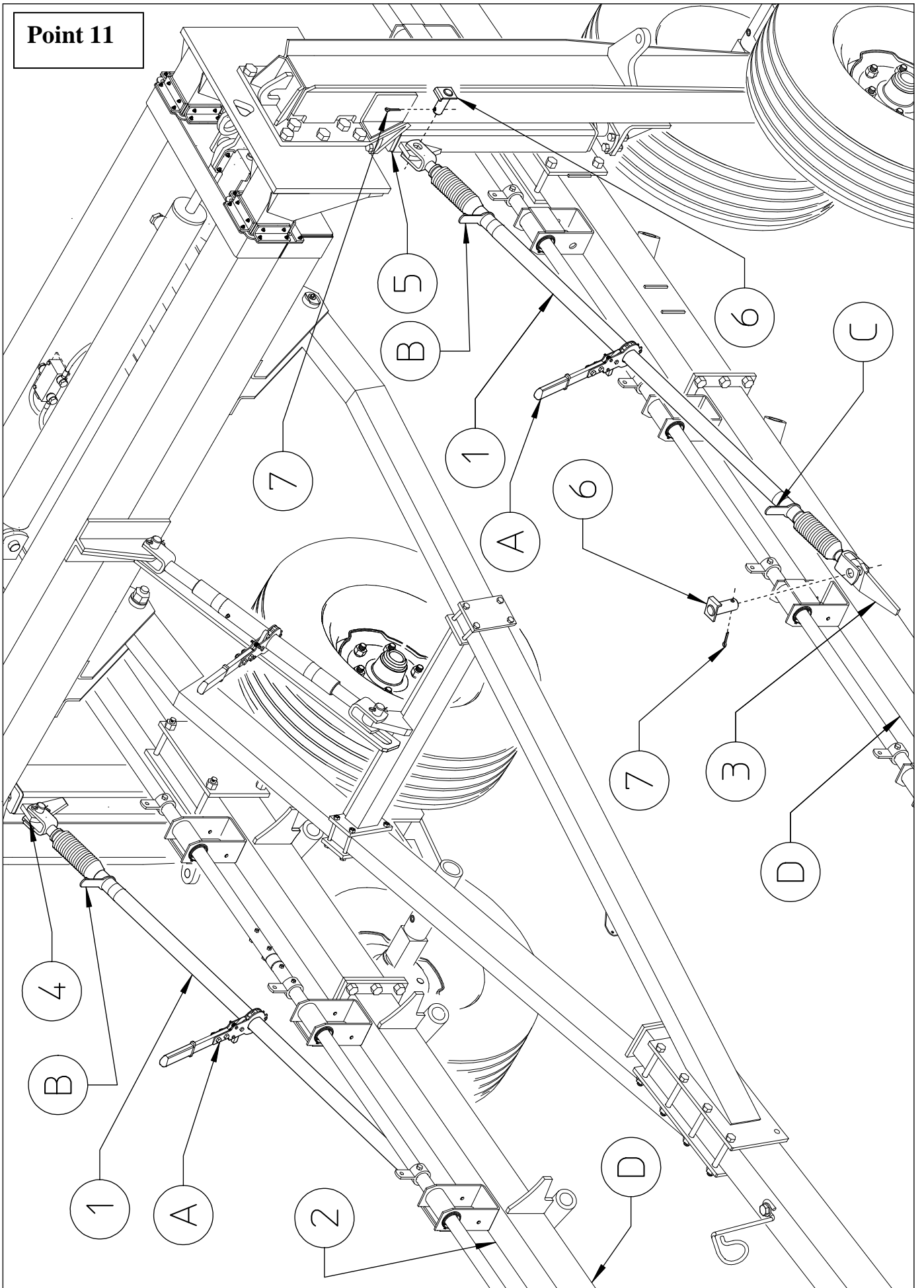

Point 11 (ATTENTION)

Continue assembly using maximum caution.

Attach the ratchet links 1 to sections 2-3 (RH and LH) and to brackets 4-5 (RH and LH) using the pins 6 and split pins 7.

If the ratchet links do not couple perfectly to brackets 2-3-4-5, loosen clamps B-C and move lever A to adjust them to the right length. Once the ratchet link 1 is correctly assembled, move lever A so that sections 2-3 are raised slightly on side "D", then retighten clamps B-C.

In this step, you will use:

Item 6: 4 pins $\varnothing 25 \times 50$ ($\varnothing 1'' \times 2''$)

Item 7: 4 split pins $\varnothing 6 \times 35$ ($0.24'' \times 1.38''$)

Point 12

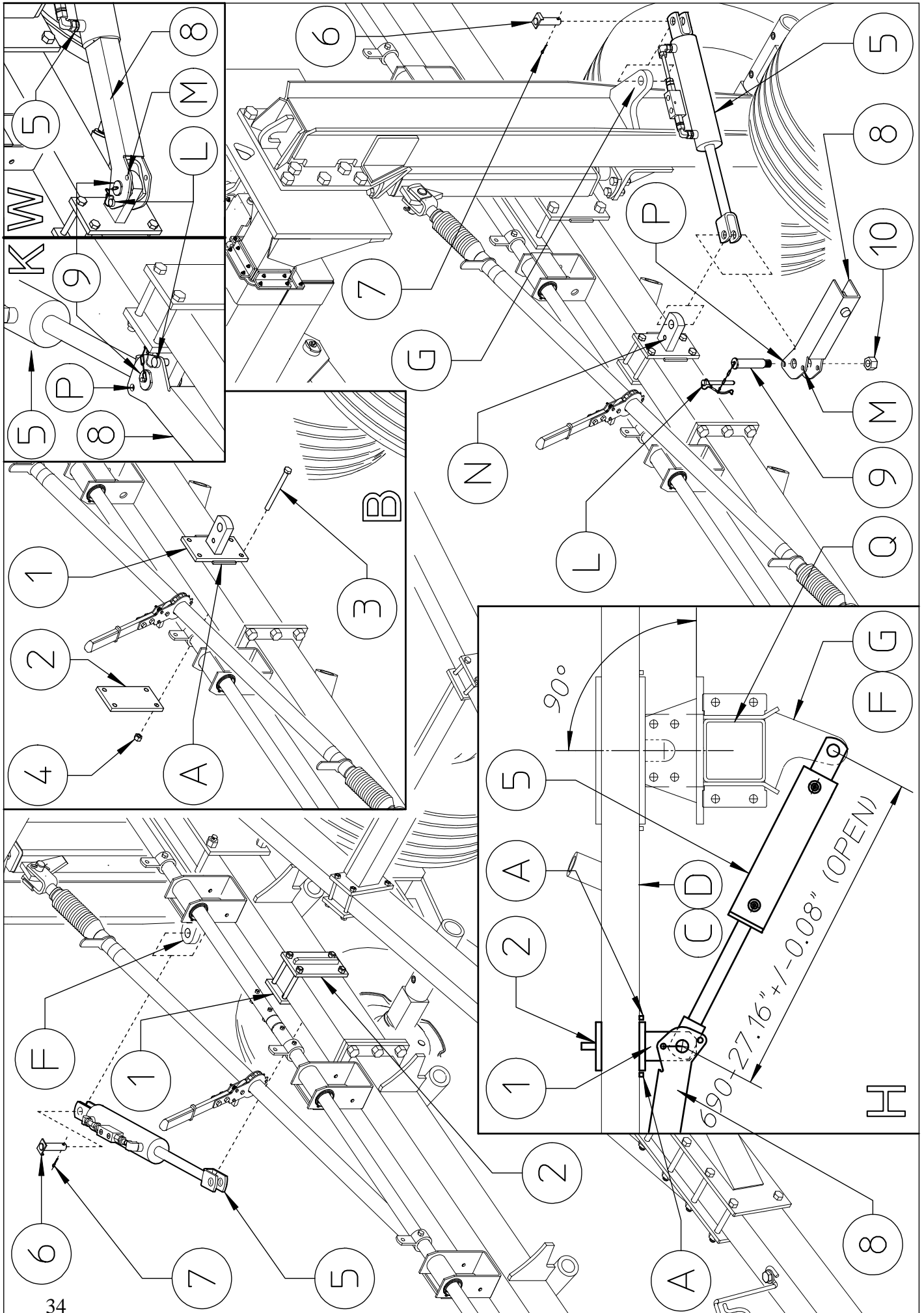

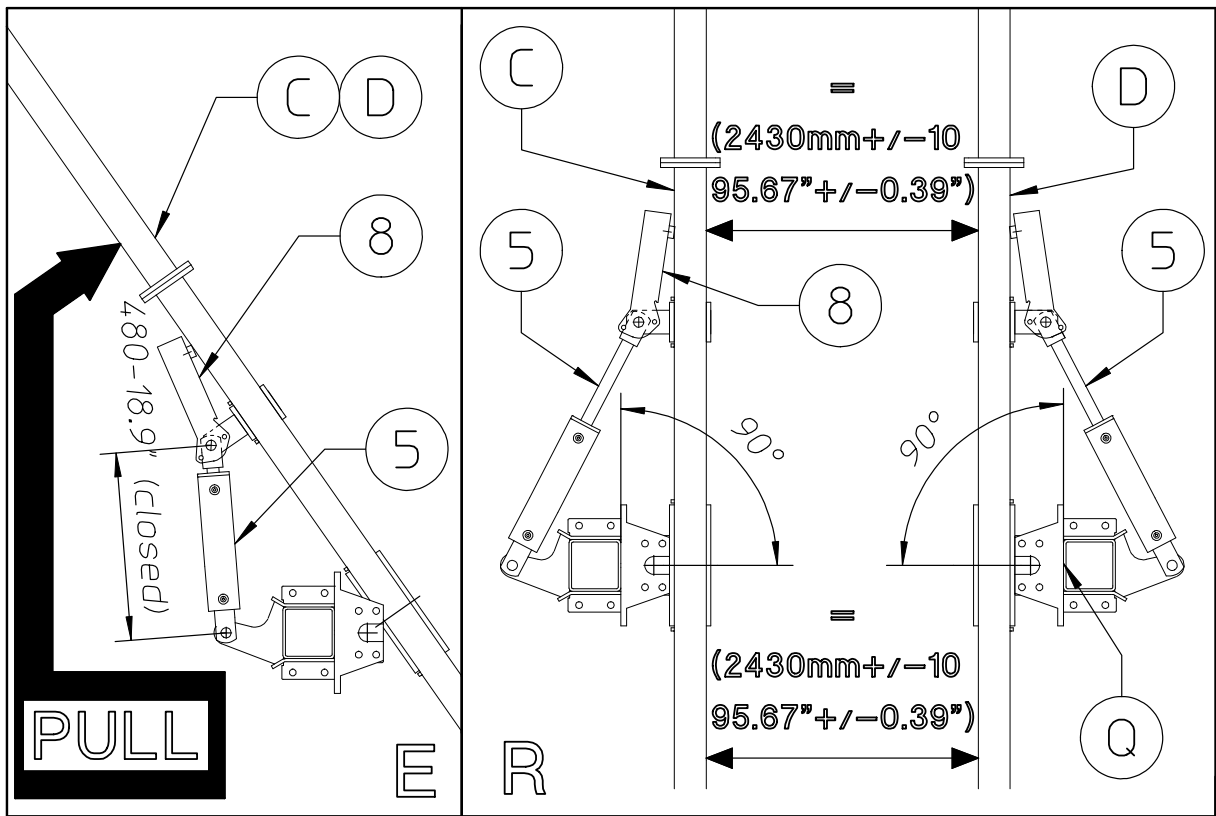

Point 12 (ATTENTION)

Continue assembly using maximum caution.

Attach brackets 1 between the position notches A (see also boxes “B”- “H”) using counterplates 2, bolts 3 and nuts 4. At this time do not tighten fully nuts 4. Now remove the caps (be careful not to allow dirt to enter) placed over the valves of cylinders 5 and extend the cylinders completely up to the length of 690 mm +/-2 – 27.16” +/- 0.08”. Note: even when the caps are removed, it may be difficult to open the cylinder because the block valve partially opposes the passage of air. In this case the cylinder shaft must be tugged until it extends completely. If this does not work, attach the closed cylinder 5 (480 mm-18.9”) according to the method indicated in following and use section “C” or “D” as a lever to extend it (see box “E”).

Attach the cylinders 5 to the brackets 1 and supports F-G (RH and LH). Fasten cylinders 5 to their supports F-G using pins 6 and split pins 7. Attach transport retainers 8 to the side of the cylinders 5 that goes to brackets 1 and lock all in place with pins 9 and nuts 10. (See also boxes “H”-“K”.) Lever 8 should be positioned as shown in the drawing in box “K” by inserting pin L (integral with pin 9) into holes M in the lever and N in bracket 1. This is the position to be used while working and also during assembly. Lever 8 should be positioned as shown in the drawing in box “W” by inserting pin L into holes P in the lever and N in bracket 1. This is the position to be used during transport.

Before fully tightening the nuts 4 make sure that sections “C” – “D” are parallel with each other or 90° with respect to the axis of piece “Q” (see boxes “H”- “R”). If these conditions do not occur, move bracket 1 forward or backward between notches A until the required position is reached. At this point fully tighten the nuts 4.

In this step, you will use:

- Item 3: n° 8 screw M12x120 (0.47“ x 4.72”)
- Item 4: n° 8 nut M12 (0.47”)
- Item 6: n° 2 pin ø25x50 (ø1“ x 2”)
- Item 7: n° 2 split pin ø6x35 (0.24” x 1.38”)
- Item 9: n° 2 pin ø25x** (ø1“ x **”)
- Item 10: n° 2 Nut M20 (0.78”)

Point 13

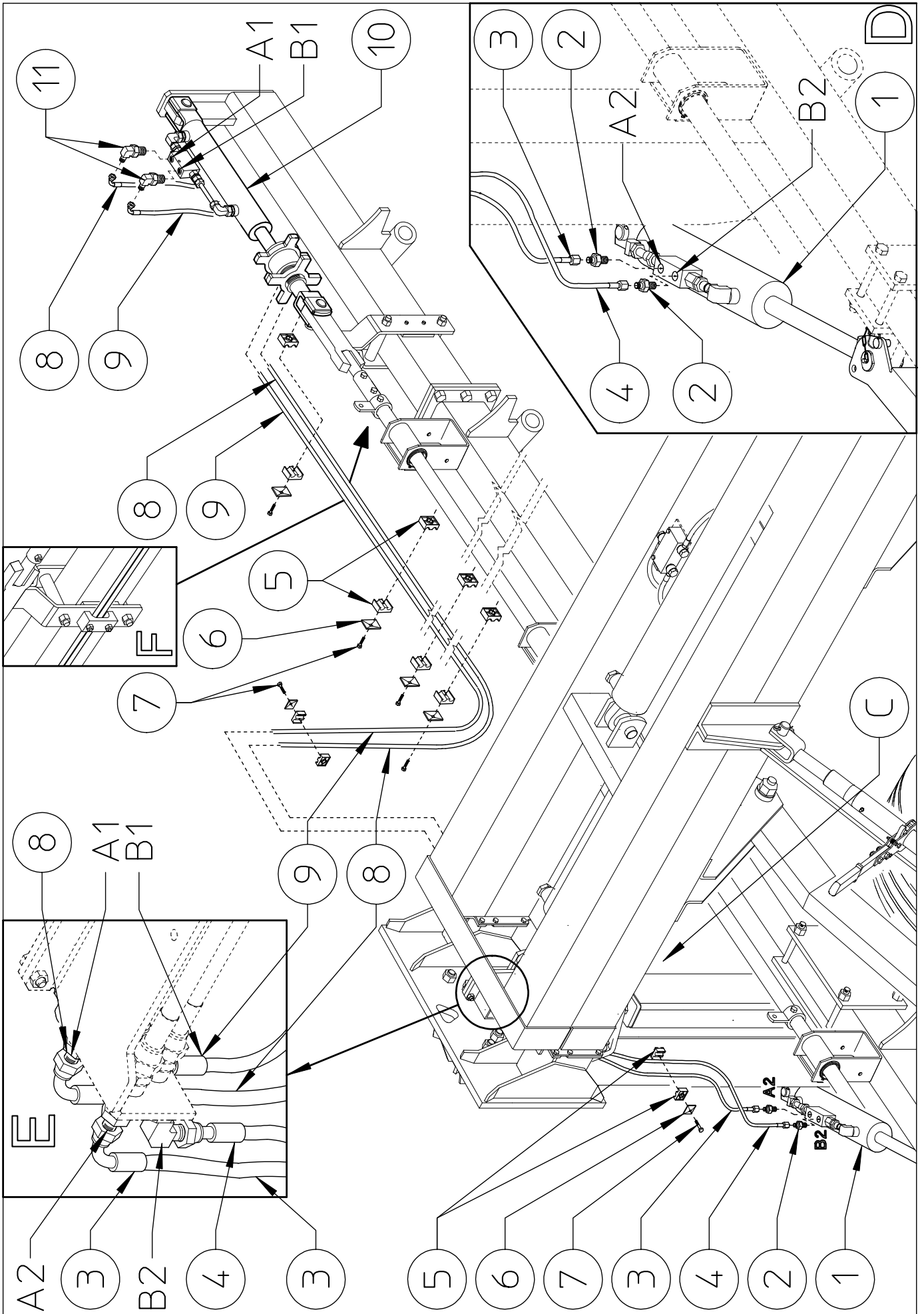

Point 13 (ATTENTION)

Prior to the assembly of arms, rake wheels and accessories, we recommend to assemble the hydraulic system in order to have more room to manoeuvre. Although the assembly of the hydraulic system requires attention, difficulties will be minimal because the most complex parts have been pre-assembled by the manufacturer. For a detailed explanation of assembly sequence, please read pages 42-43-44-45-46-47-48-49-50-51-52-53.

The hoses 3-4-8-9 to be assembled in this step may be found partially pre-assembled in the area “C” of the crosspiece assembly.

Attach fittings 2 at points A2 and B2 on the valve of cylinder 1 (see box “D”). Attach hose 3 (the one that in box “E” has a 90° end already connected to attachment A2) to fitting 2 in position A2 on the valve. Attach hose 4 (the one that in box “E” is already connected to attachment B2) to fitting 2 in position B2 on the valve. Fasten hoses 3-4 in place using semi-collars 5, clamp 6 and screws 7.

First pass the hoses 8-9 through the bracket (see box “F”).

Attach the 90° fittings 11 at points A1 and B1 on the valve of cylinder 10. Attach hose 8 (the one that in box “E” has a 90° end already connected to attachment A1) to fitting 11 in position A1 on cylinder 10. Attach hose 9 (the one that in box “E” is already connected to attachment B1) to fitting 11 in position B1 on cylinder 10. Fasten hoses 8-9 in place using semi-collars 5, clamps 6 and screws 7.

In this step, you will use:

- Item 2: n° 2 fitting $\varnothing 3/8''-1/2$ jic 37°
- Item 5: n° 12 semi-collar for $\varnothing 12$ ($\varnothing 0.47''$) tube
- Item 6: n° 6 clamp
- Item 7: n° 6 screw M6x35 (0.23''x1.38'')
- Item 11: n° 2 fitting 90° $3/8''-1/2''$ jic 37°

Point 14

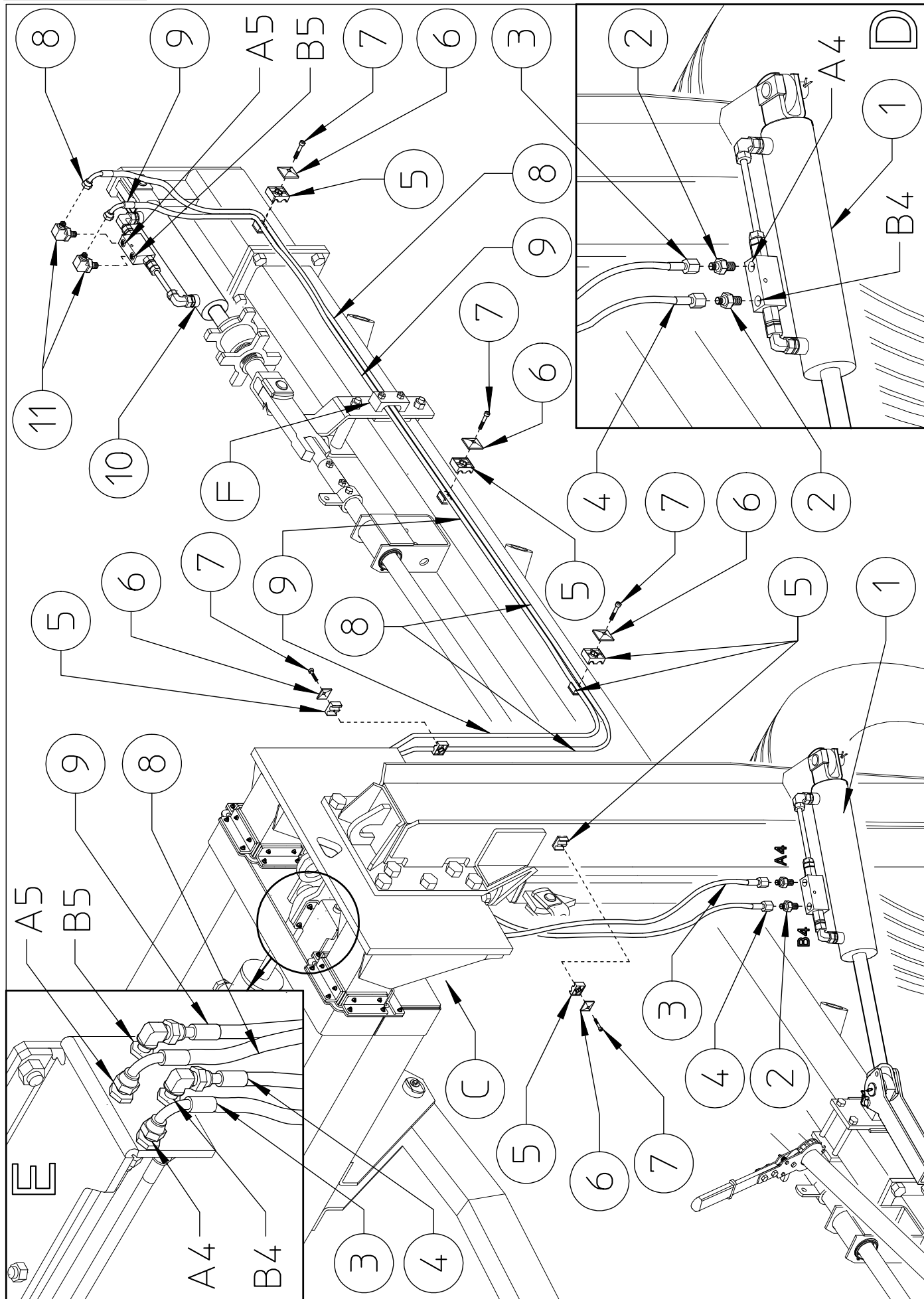

Point 14 (ATTENTION)

The hoses 3-4-8-9 to be assembled in this step may be found partially pre-assembled in the area “C” of the crosspiece assembly.

Attach fittings 2 at points A4 and B4 on the valve of cylinder 1 (see box “D”). Attach hose 3 (the one that in box “E” has a 90° end already connected to attachment A4) to fitting 2 in position A4 on the valve. Attach hose 4 (the one that in box “E” is already connected to attachment B4) to fitting 2 in position B4 on the valve. Fasten hoses 3-4 in place using semi-collars 5, clamp 6 and screws 7.

First pass the hoses 8-9 through bracket F.

Attach the 90° fittings 11 at points A5 and B5 on the valve of cylinder 10. Attach hose 8 (the one that in box “E” has a 90° end already connected to attachment A5) to fitting 11 in position A5 on cylinder 10. Attach hose 9 (the one that in box “E” is already connected to attachment B5) to fitting 11 in position B5 on cylinder 10. Fasten hoses 8-9 in place using semi-collars 5, clamps 6 and screws 7.

In this step, you will use:

- Item 2: n° 2 fitting $\varnothing 3/8''-1/2$ jic 37°
- Item 5: n° 10 semi-collar for $\varnothing 12$ ($\varnothing 0.47''$) tube
- Item 6: n° 5 clamp
- Item 7: n° 5 screw M6x35 (0.23''x1.38'')
- Item 11: n° 2 fitting 90° $3/8''-1/2''$ jic 37°

Point 15

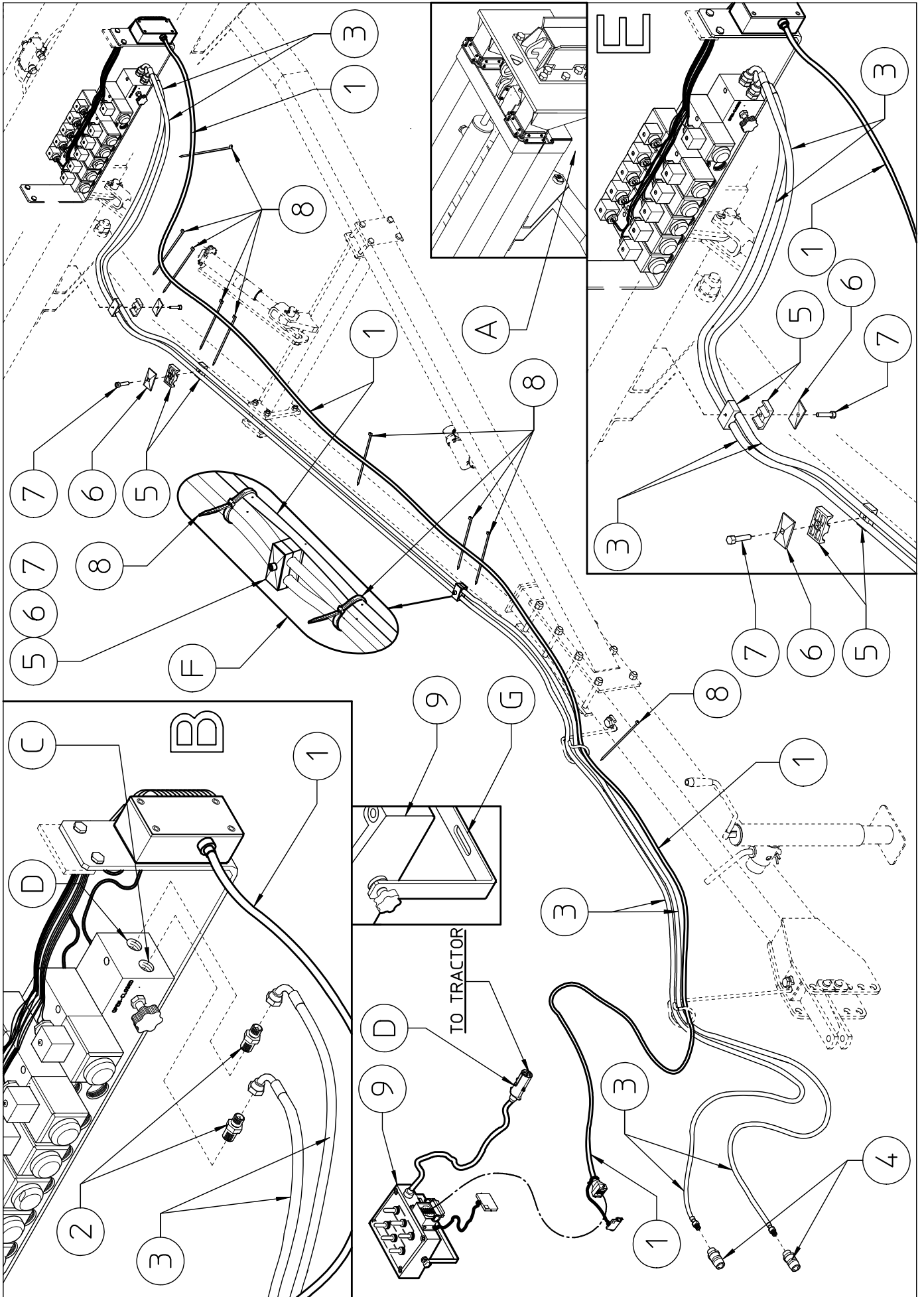

Point 15 (ATTENTION)

The electric cable 1 may be found wound in the area “A” of the crosspiece assembly. Handle it carefully in order to avoid damage. First assemble hoses 3 and then the electric cable 1.

Attach fittings 2 to openings C-D in the solenoid valve assembly (see box “B”). Attach hoses 3 to fittings 2 (see box “B”). Lay hoses 3 all along the drawbar. Attach rapid couplings 4 to the ends of hoses 3. Then fasten hoses 3 to the respective openings using semi-collars 5, clamps 6 and screws 7 (see also box “E”). Now lay the electric cable 1 next to hoses 3 and fasten it using clamps 8 (see detail “F”) in the specified points. Mount the control box 9 to the driving position of the tractor using the slots “G” on the support. Connect the plug at the end of the electric cable 1 to the control box 9. Connect the plug “H” of the control box 9 to the tractor plug. For an explanation of these operations, please refer to points 16-17 on pages 42-43-44-45-46-47-48-49-50-51-52-53.

In this step, you will use:

- Item 2: n° 2 fitting 1/2”-3/4” jic 37°
- Item 4: n° 2 rapid coupling 1/2”
- Item 5: n° 6 semi-collar for ø18 (ø0.71”) tube
- Item 6: n° 3 clamp
- Item 7: n° 3 screw M8x35 (0.31”x1.38”)
- Item 8: n° 9/10 clamp

Point 16

Wiring diagram of the electric-hydraulic system

Characteristics of electric components:

Power supply: 12 V DC

Characteristics of solenoid valve coils: 12 V DC – 30 Watt – 2,5 A

Characteristics of hydraulic components:

Working pressure of hoses, fittings, cylinders etc. : 200 bar – 2800 psi

Type of fittings, joints etc.: gas BSPP 60° cone and jic 37°

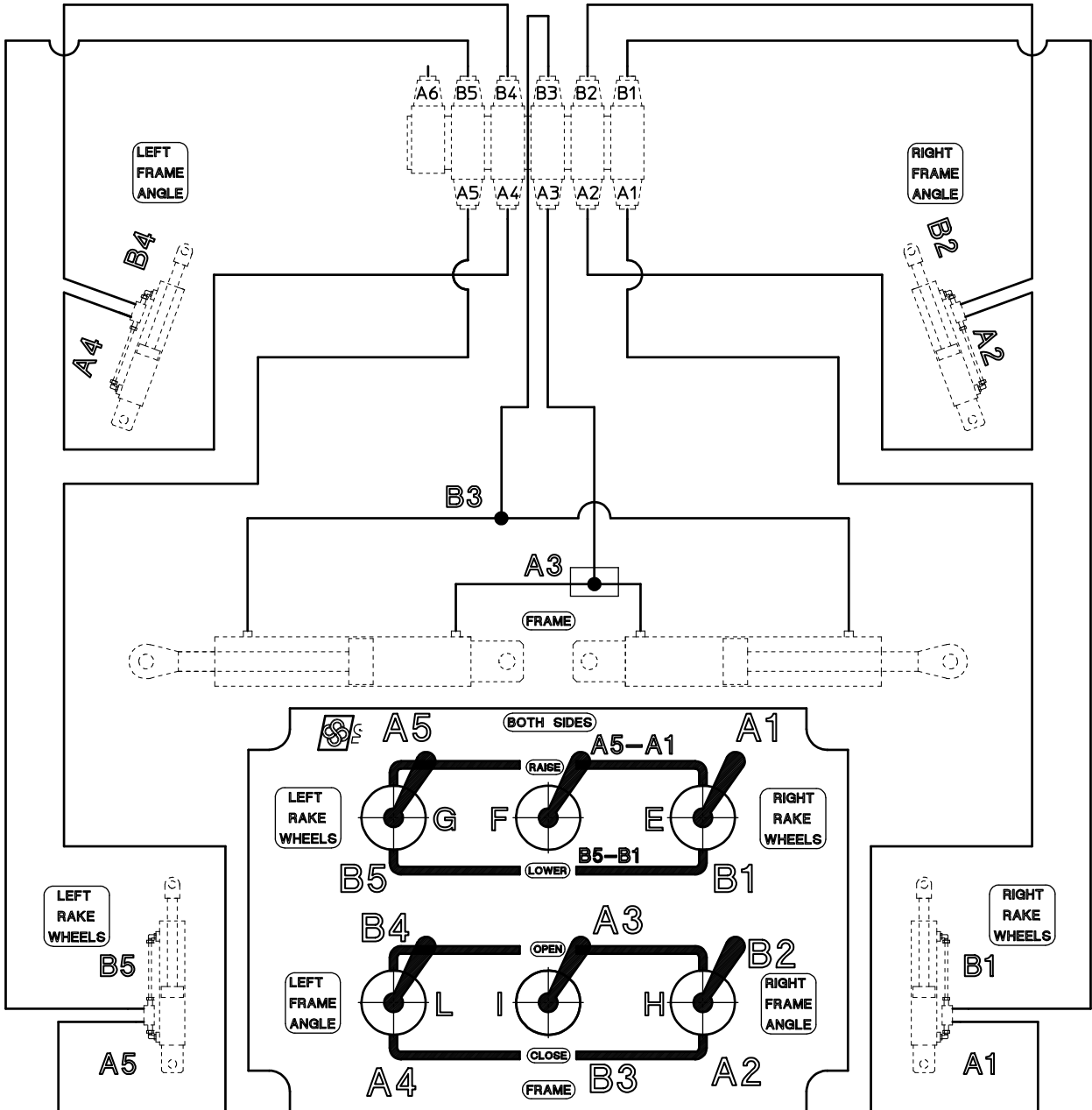
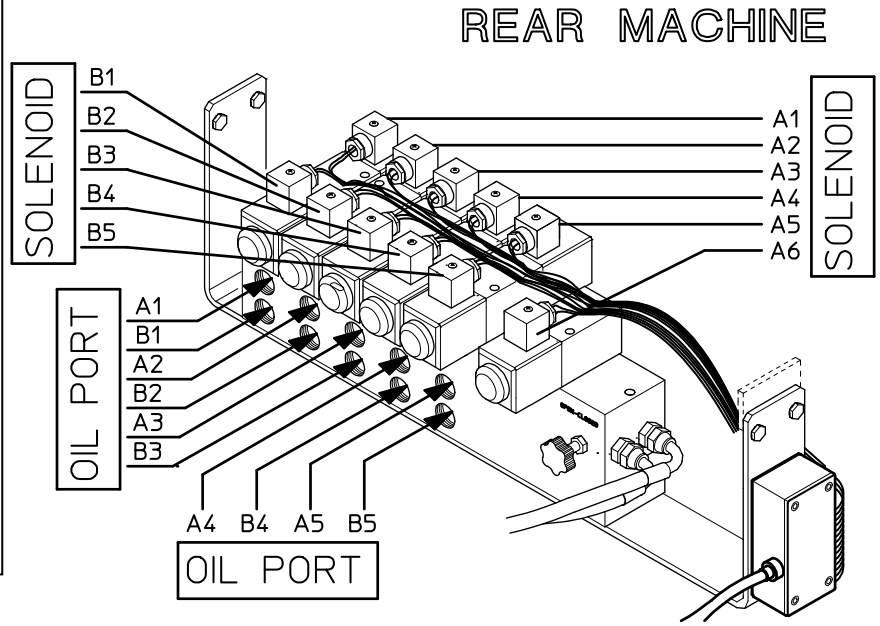

Point 16

ELECTRICAL DIAGRAM

Characteristics of electric components:

Power supply: 12 V DC

Characteristics of solenoid valve coils: 12 V DC – 30 Watt – 2,5 A

Note: Box “H” contains not only the connections to the solenoids in the valve assembly, but also the wiring that makes it possible to apply the lights to the machine for road use. See diagram.

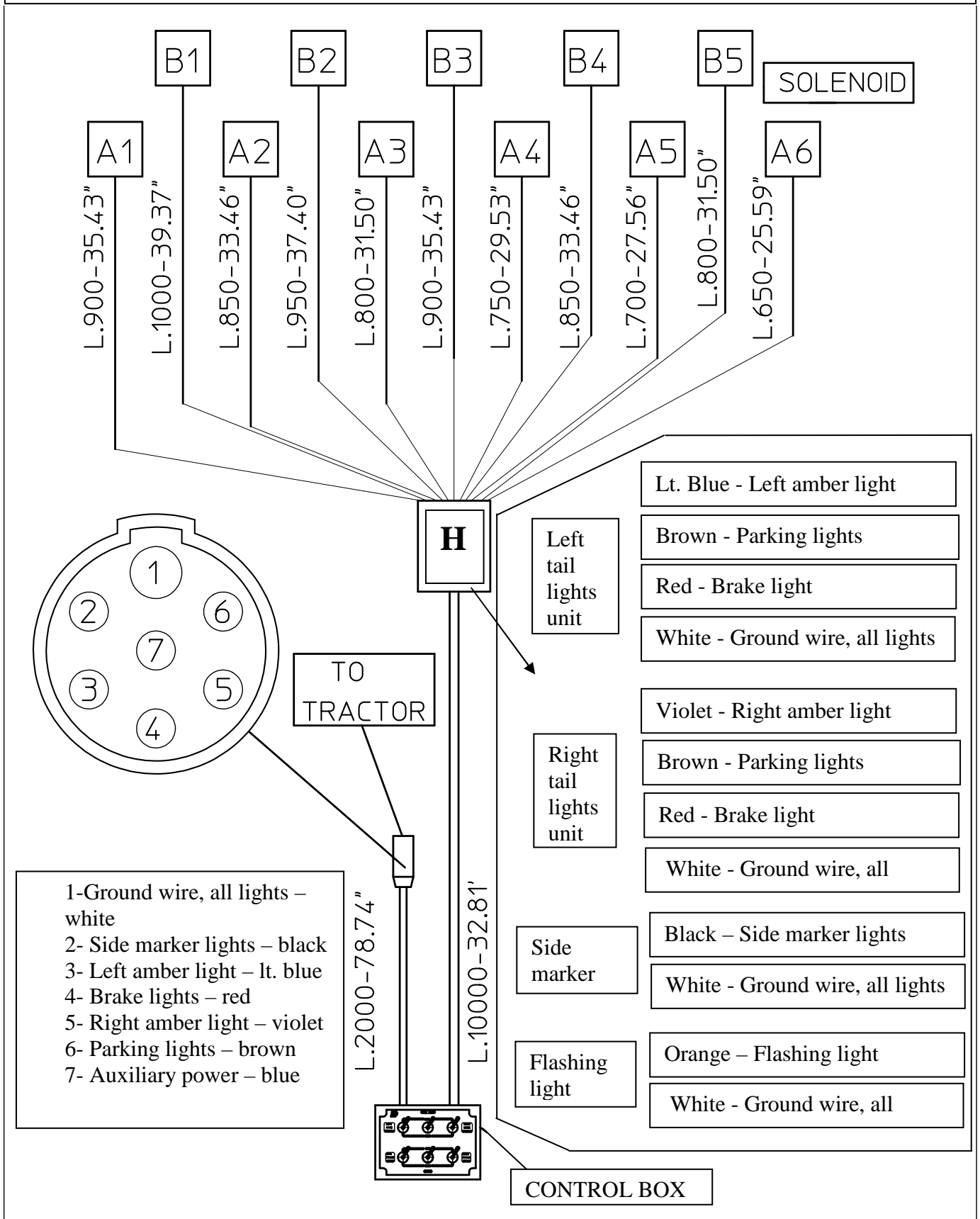

Point 17

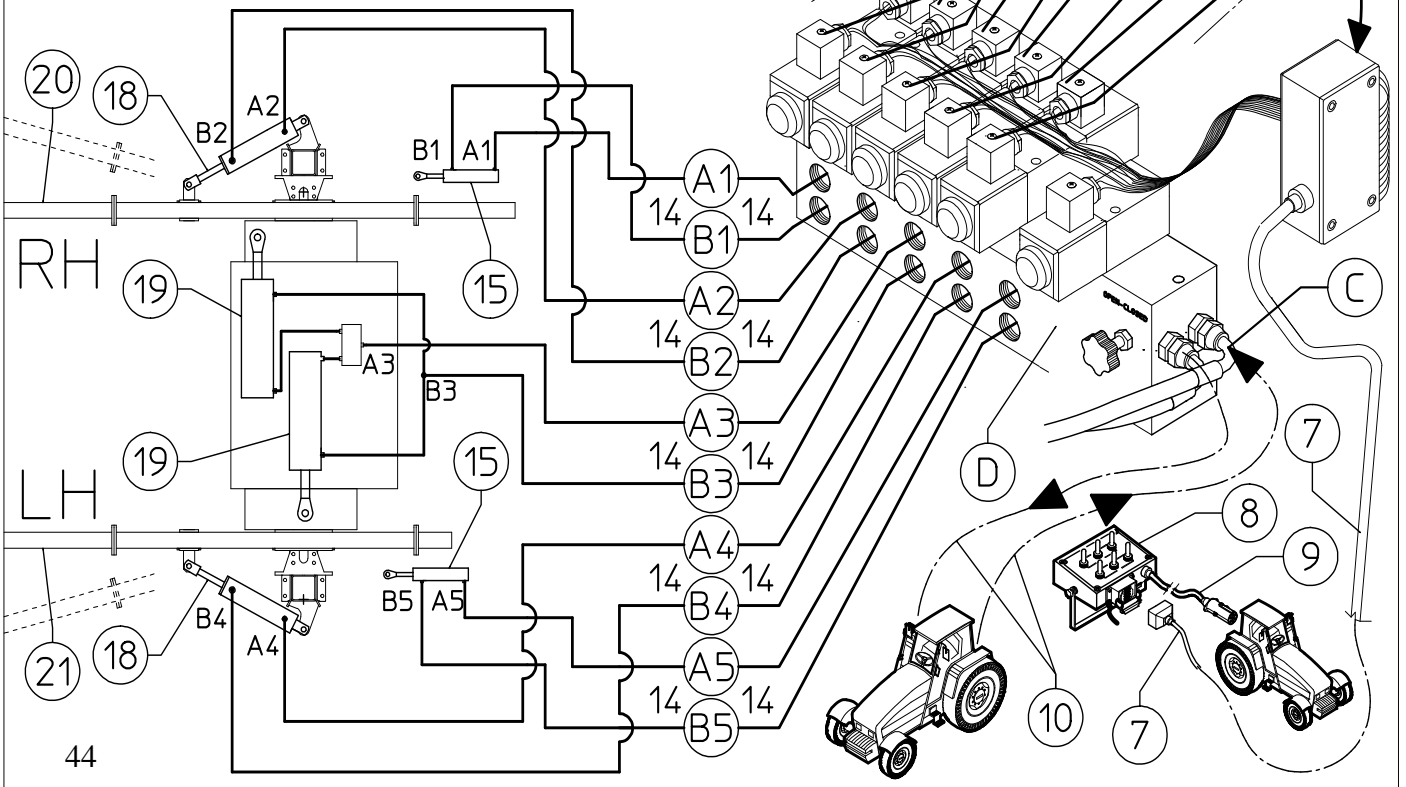
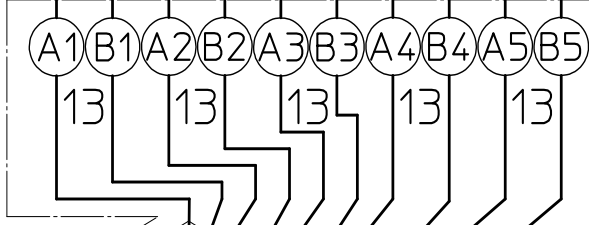
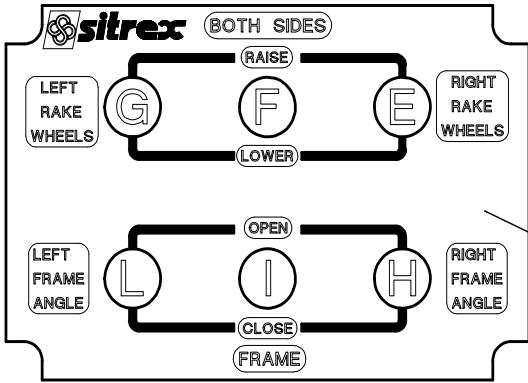
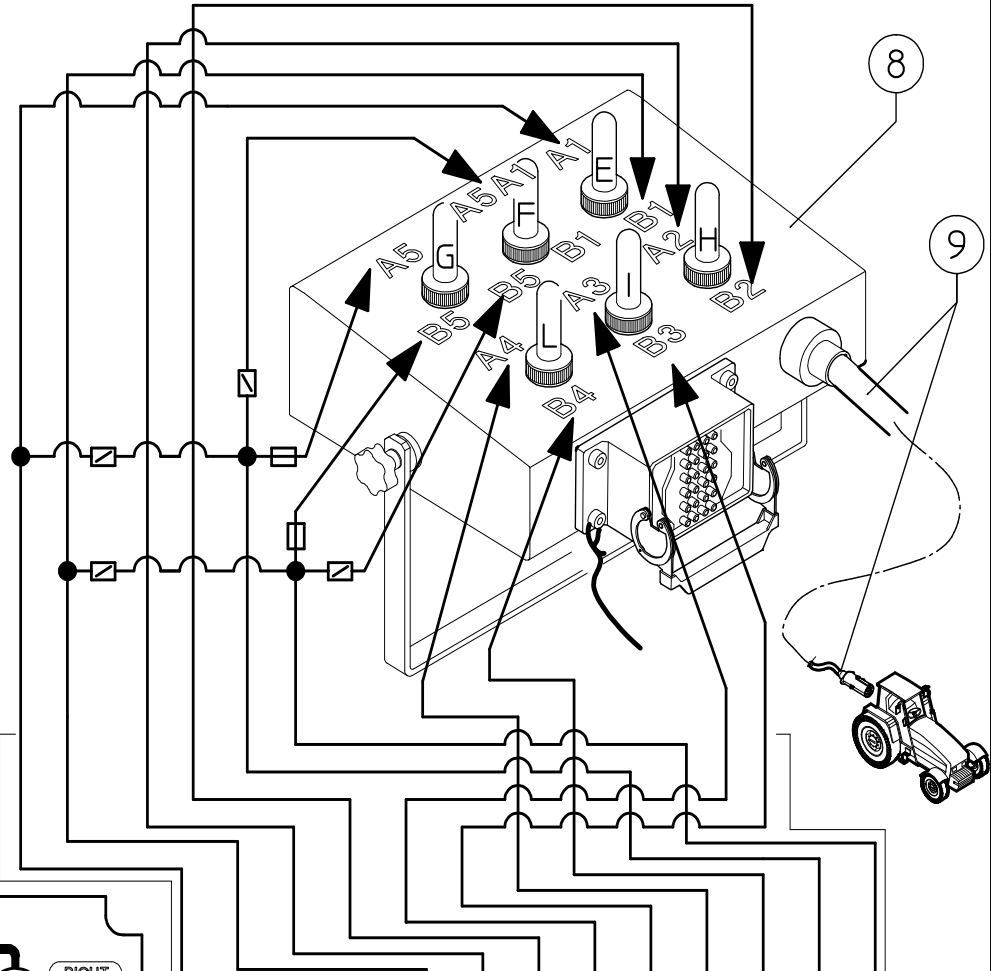
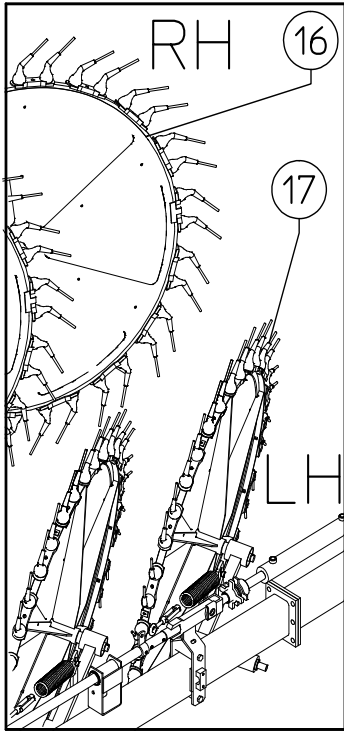

Point 17

Wiring diagram of the electric-hydraulic system

Characteristics of electric components:

Power supply: 12 V DC

Characteristics of solenoid valve coils: 12 V DC– 30 Watt – 2,5 A

Characteristics of hydraulic components:

Working pressure of hoses, fittings, cylinders etc. : 200 bar – 2800 psi

Type of fittings, joints etc.: gas BSPP 60° cone and jic 37°

At this time, the machine may be connected to the tractor for a testing of all working elements, because the brackets, stars and accessories are not yet assembled and it is still possible to make any correction, if required. If however it is necessary to assemble stars and accessories, please proceed to the next point.

Connect electric cable 7 to control box 8 using the respective plug.

The power cable 9 for the control box 8 must be plugged into the connector on the tractor.

If the tractor being used does not have a connector or if it has one that is not compatible with that of the machine, replace and/or make the necessary modifications to the machine plug. Have the replacement and/or modifications done by a qualified person, because a connection error could cause significant damage to the electrical system.

Note: to avoid damage and/or dirt from entering the multiple connector on box 8 and on cable 7, cover them with covers “K” and “W” when they are not connected to each other. Pay attention also to the multiple connector “T” on cable 9.

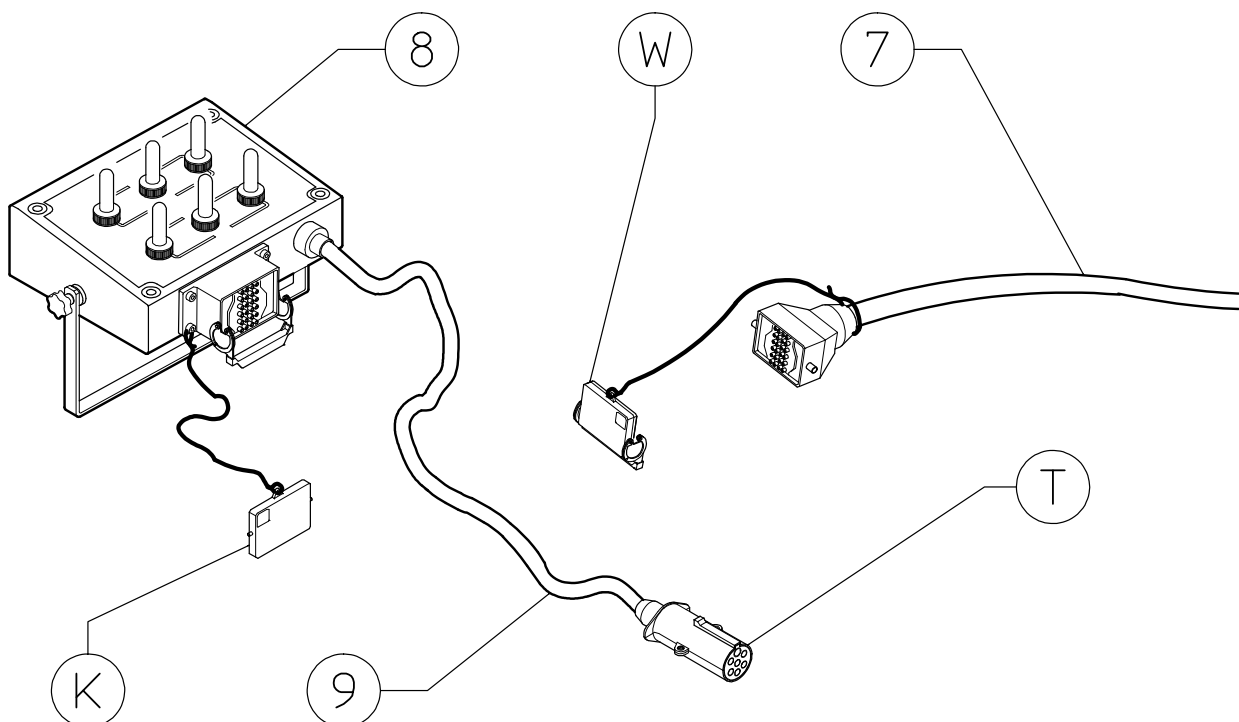

Point 17

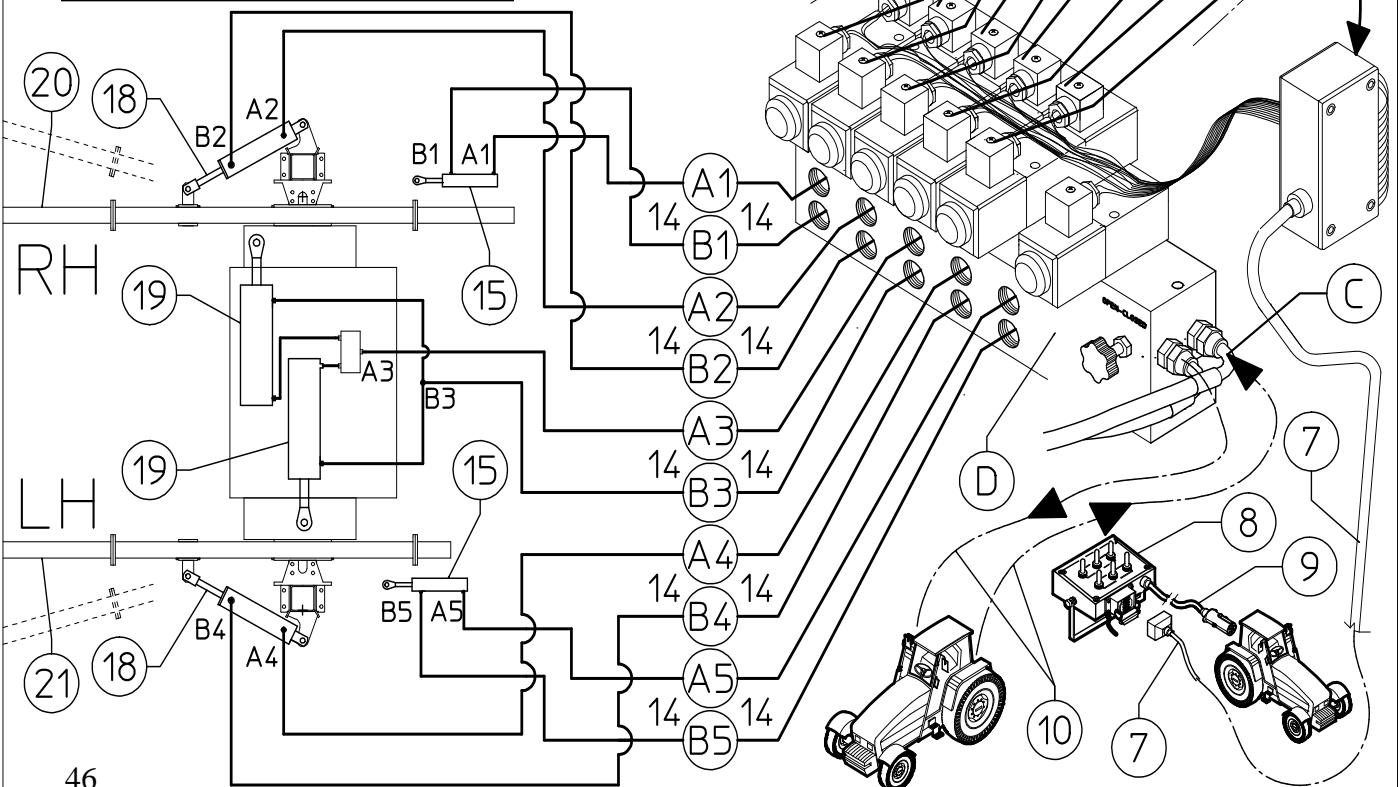
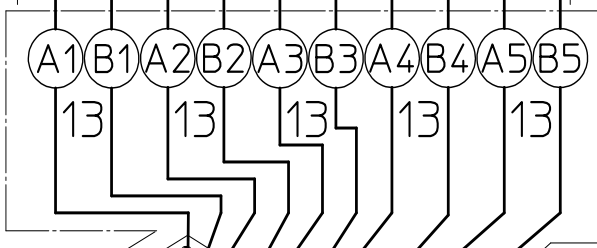
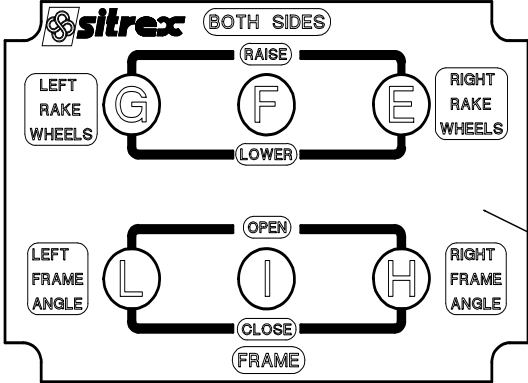
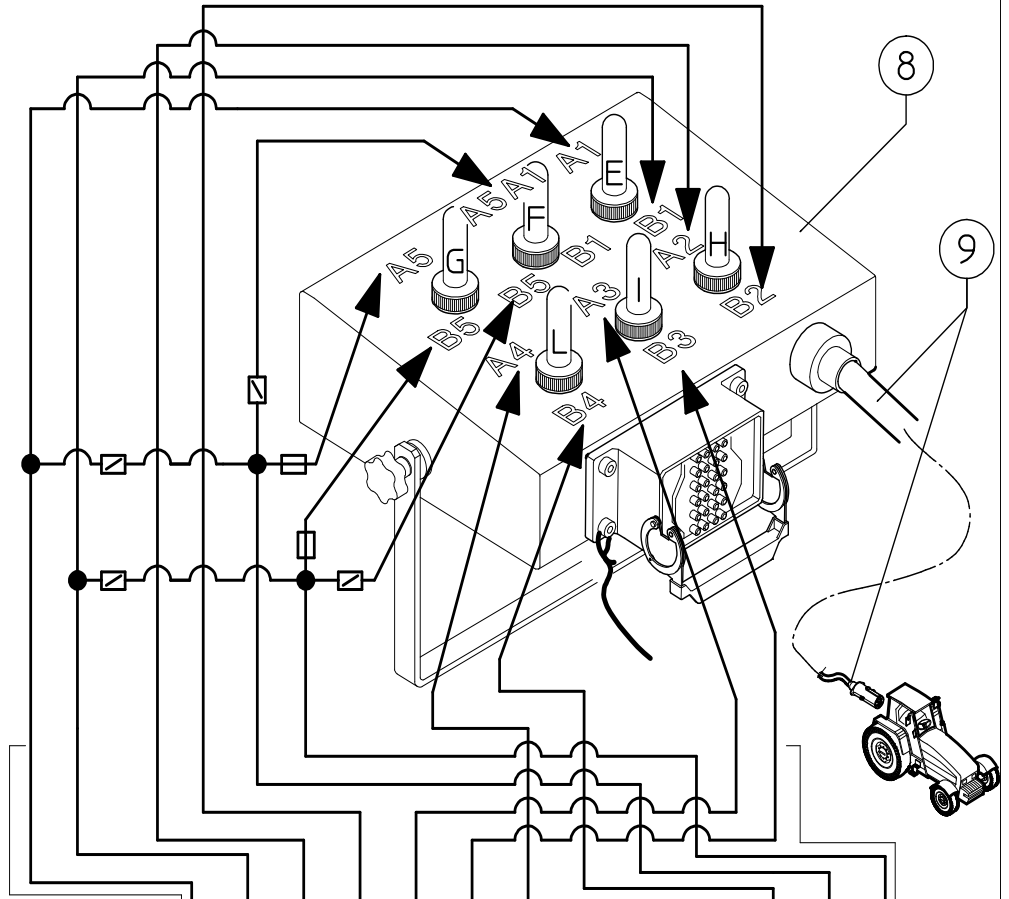
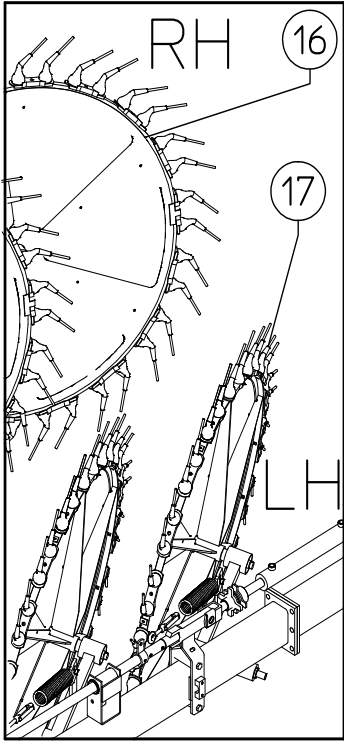

At this point connect hoses to the tractor oil intakes. The machine's hydraulic system allows working with any type of tractor, as it has a knob for opening or closing the hydraulic circuit. Read carefully the notice below, which is also applied to the machine in the form of a sticker (for location of the sticker, see pages 8-9 of this manual).

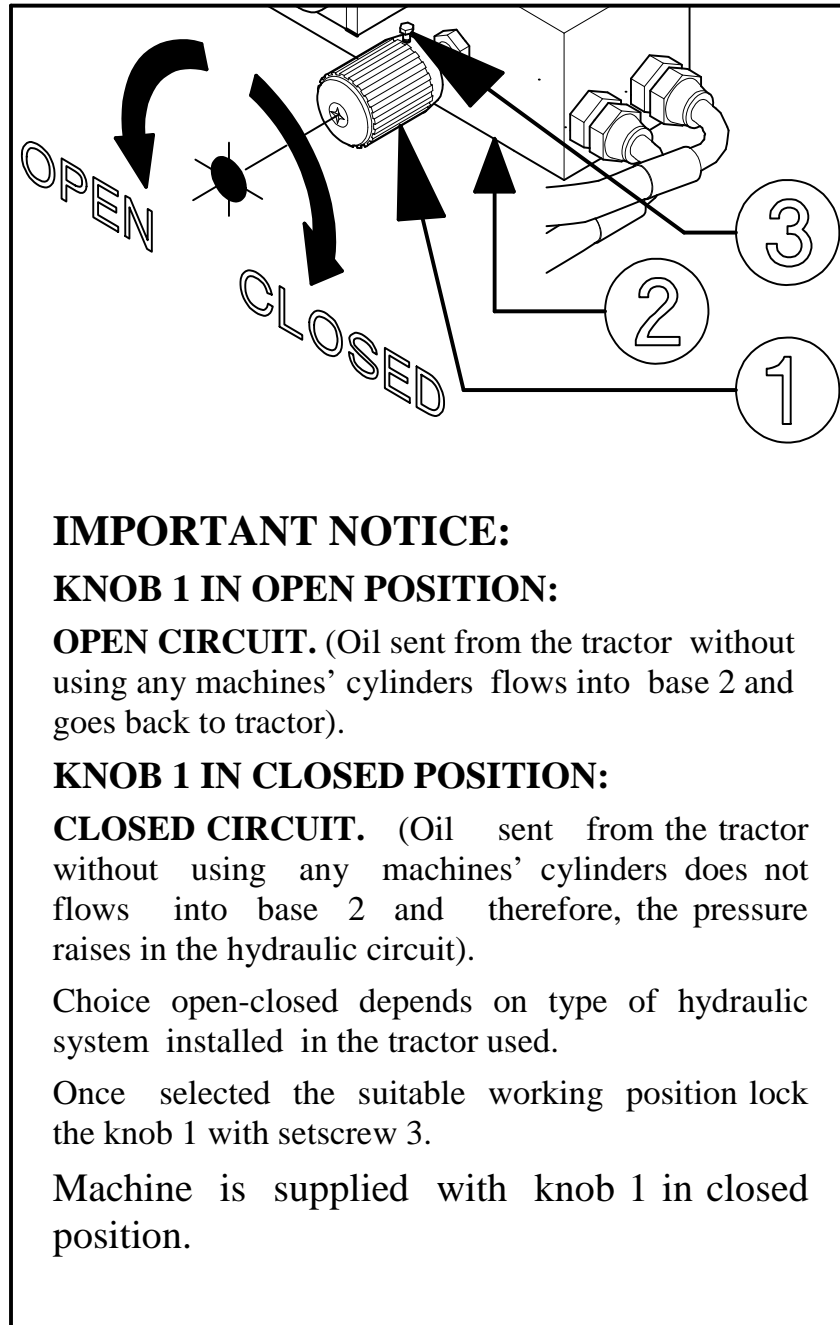

Now you can start introducing oil into the hydraulic circuits. Note: hose 10 in which the oil must enter is the one that is connected to point "C" of the valve assembly "D" whereas in the other hose 10 the oil returns to the tractor.

Point 17

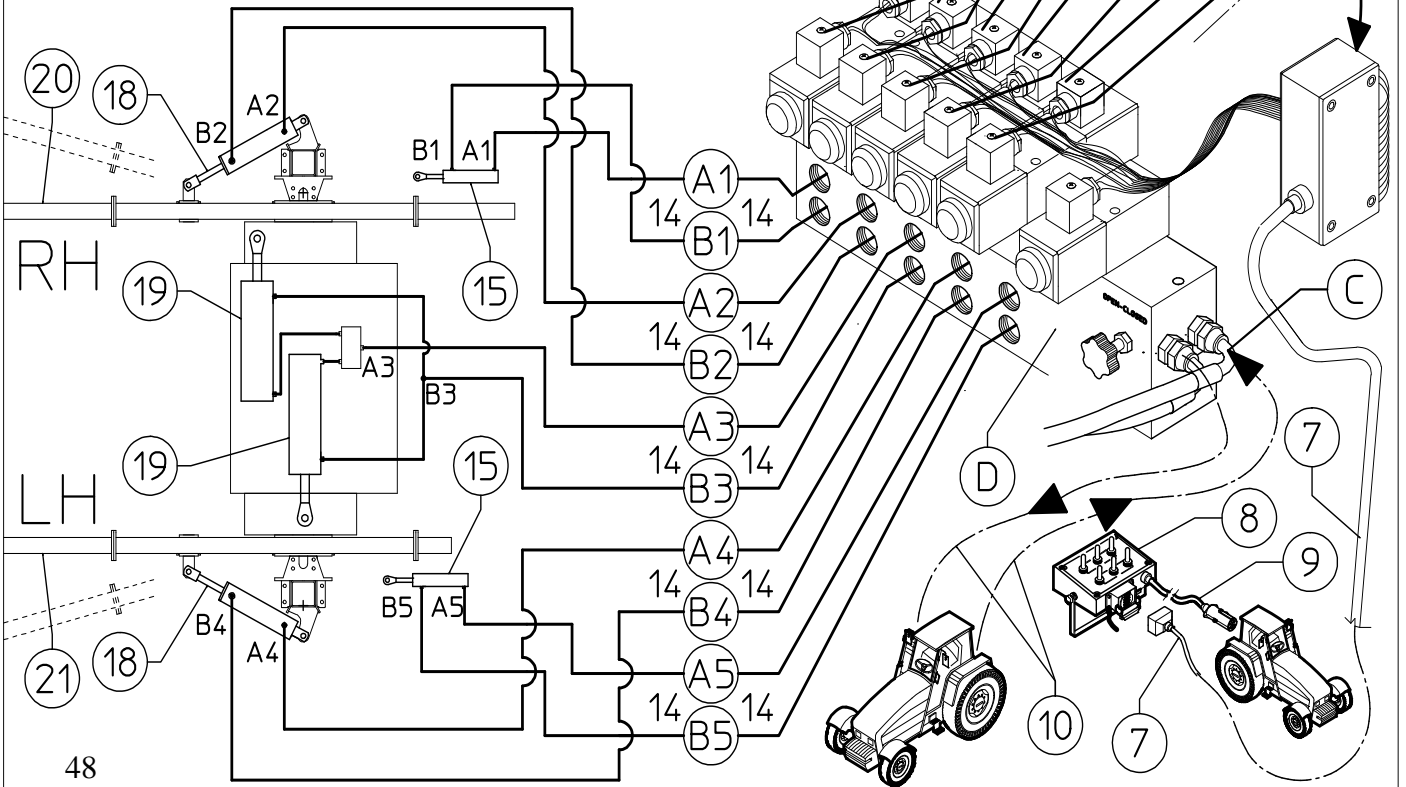
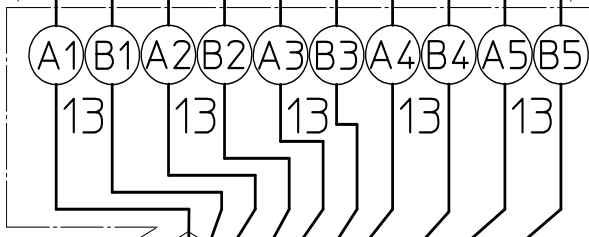
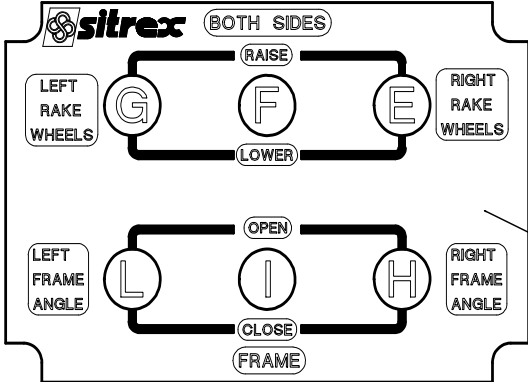
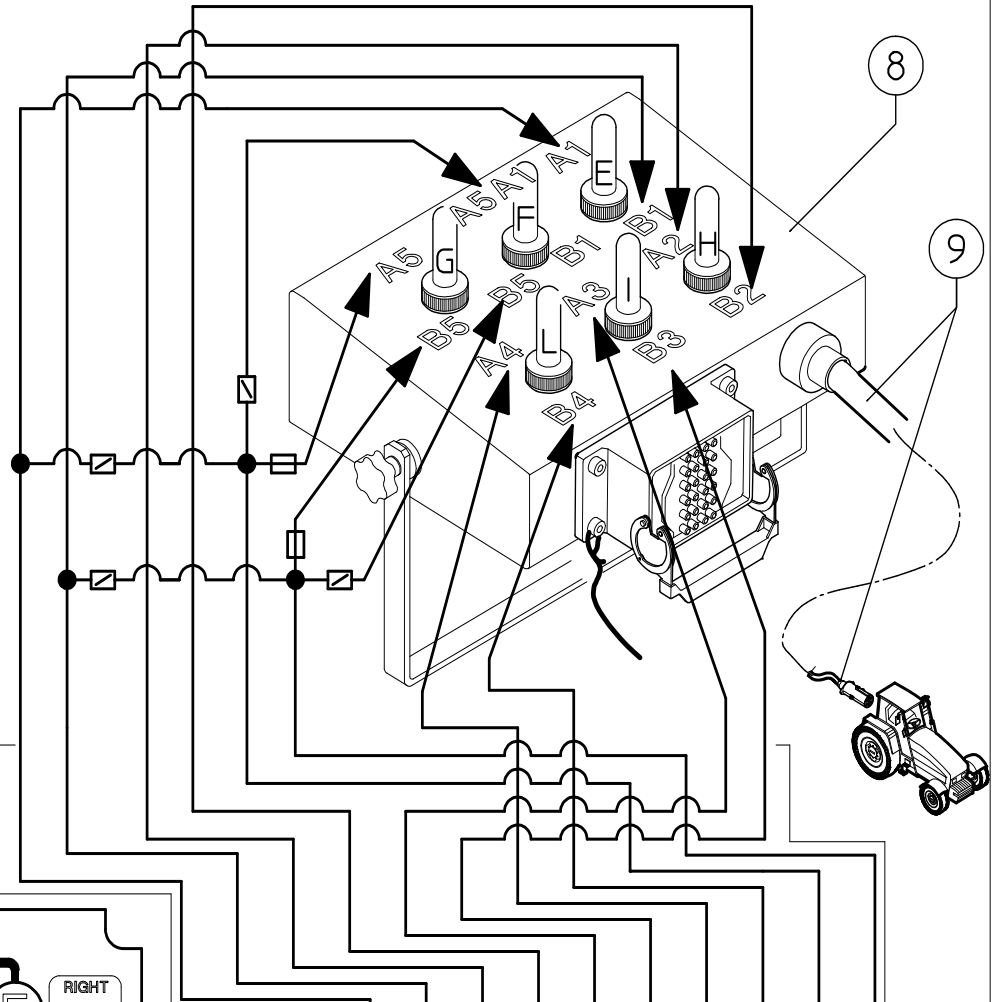
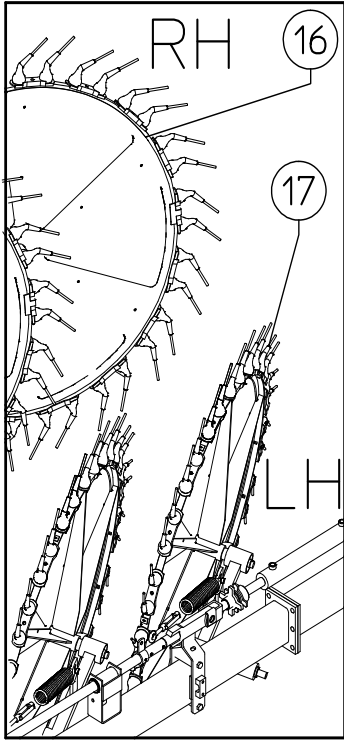

If the joint of hoses 10 is inverted, the elements of the tractor will not work. However no damage may occur, because the hydraulic system has been designed to avoid this. In this case, it will be sufficient to re-invert the position of hoses 10 on the brackets of the tractor. Be very careful once oil has entered the circuit, because machine parts will start moving and will become dangerous for anyone within their range.

While keeping oil flowing from the tractor to the valve assembly “D”, press the buttons “E-F-G-H-I-L” of the control box 8 in a sequence in both directions. They will control the solenoid valves (13 A1-B1, 13 A2-B2 and next) so that oil may go through the hoses (14 A1-B1, 14 A2-B2 and next) up to cylinders 15 (RH and LH), 18 (RH and LH) and 19 (RH and LH). Open and close the cylinders 15-18-19 several times, in order to bleed air from circuit. First of all the crosspieces must be opened to the maximum width of 4’ to avoid having the rake sections knock against each other at the rear of the machine when they are moved with the H-L buttons. Do several open/close cycles – if possible with the machine in movement or in any event on a surface that allows the transversal movement of the wheels – using button I in the A3 and B3 position, so as to correctly fill the cylinders 19, then carry out the same procedures with the other buttons to set up the other cylinders.

Point 17

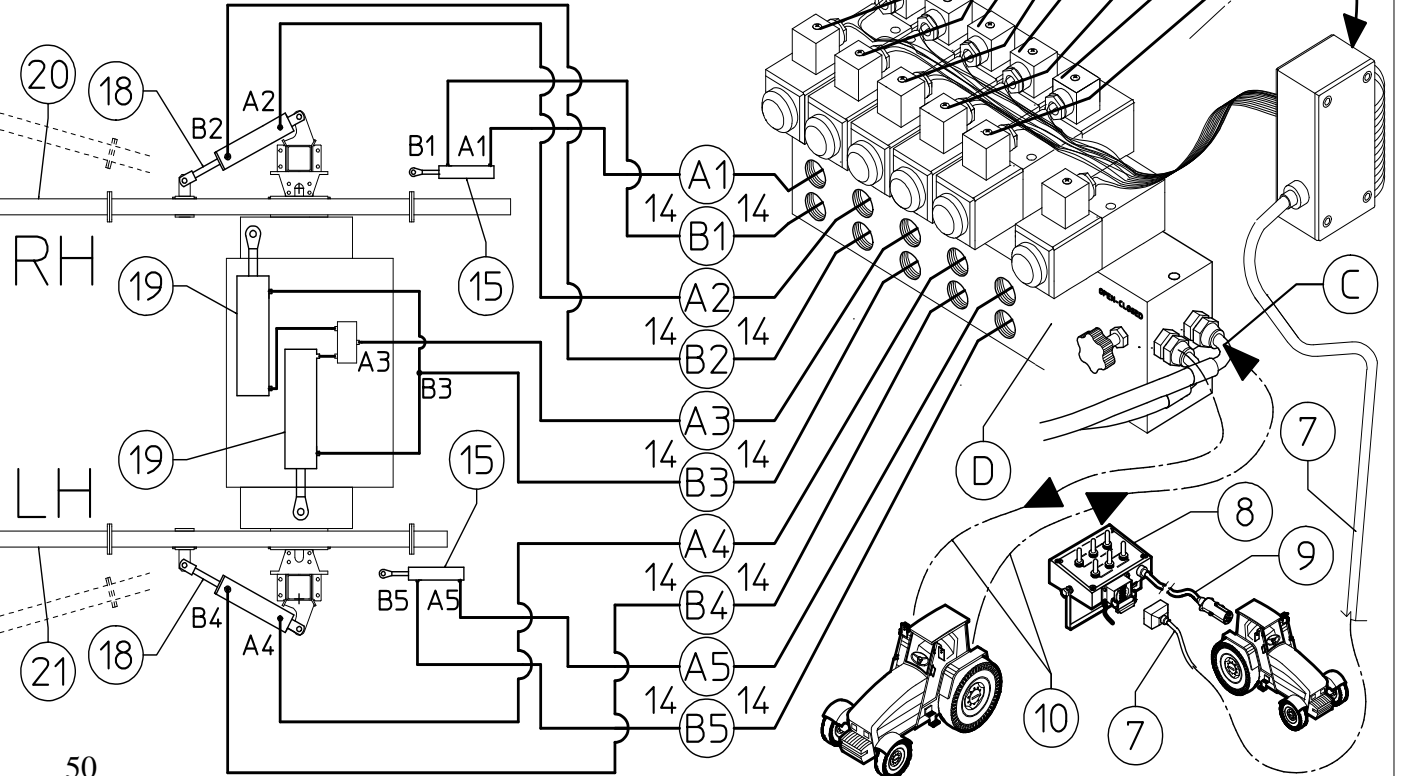
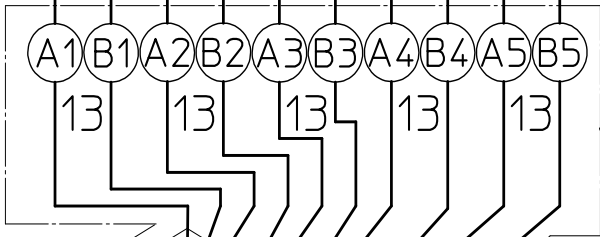
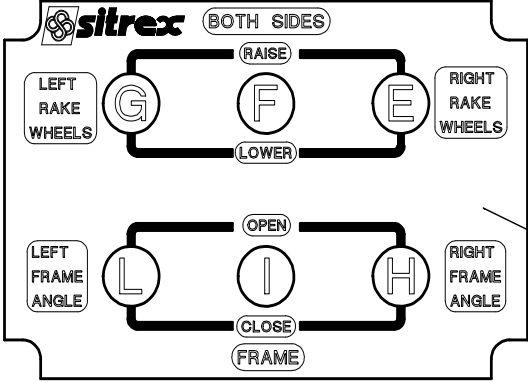
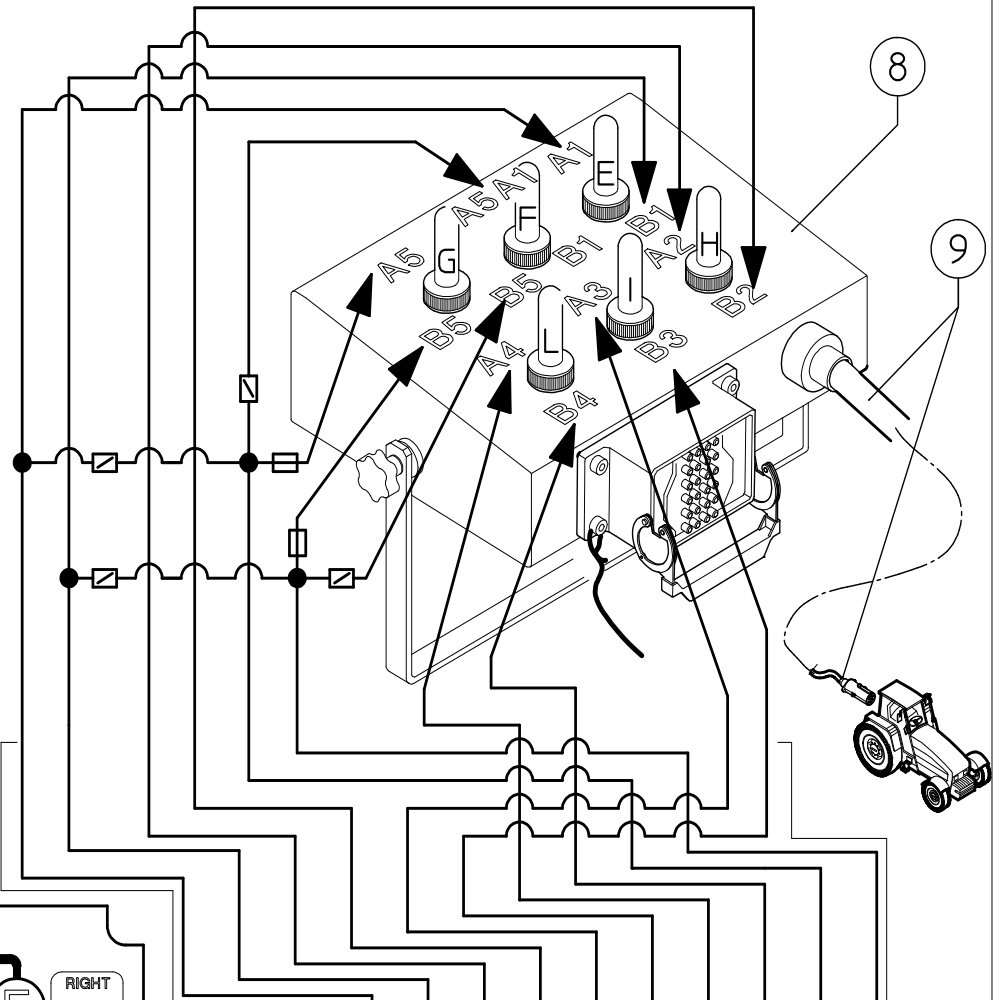
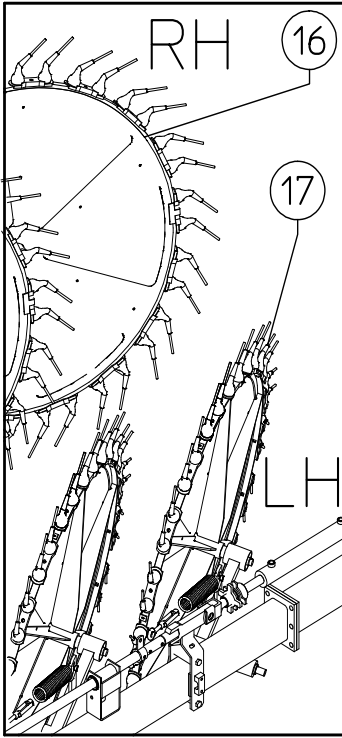

While operating the system, keep the following in mind:

1) When button “E” (the one bearing the caption “RIGHT RAKE WHEELS” in control box 8) is pushed towards A1, it acts on coil 13 A1 which – through hose 14 A1 (actually through a set of hoses and fittings that will be referred to as 14 A1 for simplicity and this applies to all) sends oil to the back side A1 of RH cylinder 15, making it go up. The resulting effect is the rising of stars 16 on the RH side of the machine, shifting from working mode to transport mode.

2) When button “E” (the one bearing the caption “RIGHT RAKE WHEELS” in control box 8) is pushed towards B1, it acts on coil 13 B1 which – through hose 14 B1 – sends oil to the front side B1 of RH cylinder 15, making it lower. The resulting effect is the lowering of stars 16 on the RH side of the machine, shifting from transport mode to working mode.

3) When button “F” (the one bearing the caption “BOTH SIDES RAISE/LOWER” in control box 8) is pushed towards A1-A5 (raise), it acts on coils 13 A1-A5 which – through hoses 14 A1-A5 – send oil simultaneously to the back sides A1-A5 of cylinders 15 (RH and LH) making them go up. The resulting effect is the simultaneous rising of stars 16 and 17 on the RH and LH sides of the machine, shifting from working mode to transport mode.

4) When button “F” (the one bearing the caption “BOTH SIDES RAISE/LOWER” in control box 8) is pushed towards B1-B5 (lower), it acts on coils 13 B1-B5 which – through hoses 14 B1-B5 – simultaneously send oil to the back sides B1-B5 of cylinders 15 (RH and LH) making them lower. The resulting effect is the simultaneous lowering of stars 16 and 17 on the RH and LH sides of the machine, shifting from transport mode to working mode.

5) When button “G” (the one bearing the caption “LEFT RAKE WHEELS” in control box 8) is pushed towards A5, it acts on coil 13 A5 which – through hose 14 A5 – sends oil to the back side A5 of LH cylinder 15, making it go up. The resulting effect is the rising of stars 17 on the LH side of the machine, shifting from working mode to transport mode.

6) When button “G” (the one bearing the caption “LEFT RAKE WHEELS” in control box 8) is pushed towards B5, it acts on coil 13 B5 which – through hose 14 B5 – sends oil to the front side B5 of LH cylinder 15, making it lower. The resulting effect is the lowering of stars 17 on the LH side of the machine, shifting from transport mode to working mode.

7) When button “H” (the one bearing the caption “RIGHT FRAME ANGLE” in control box 8) is pushed towards A2, it acts on coil 13 A2 which – through hose 14 A2 – sends oil to the back side A2 of RH cylinder 18, making it rise. The resulting effect is the transition of RH section 20 from the open working position to the closed transport position.

Point 17

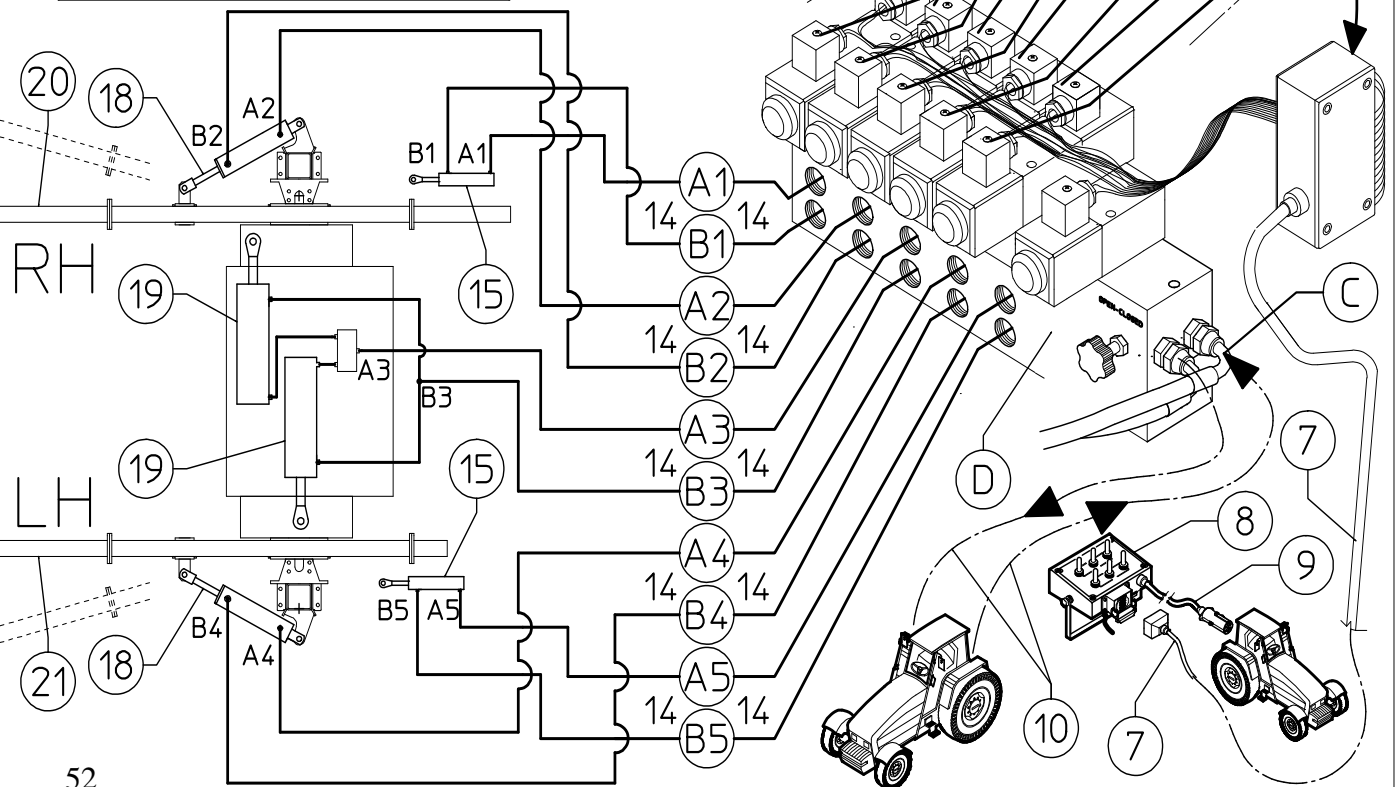
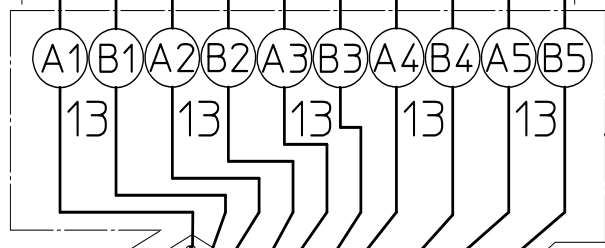
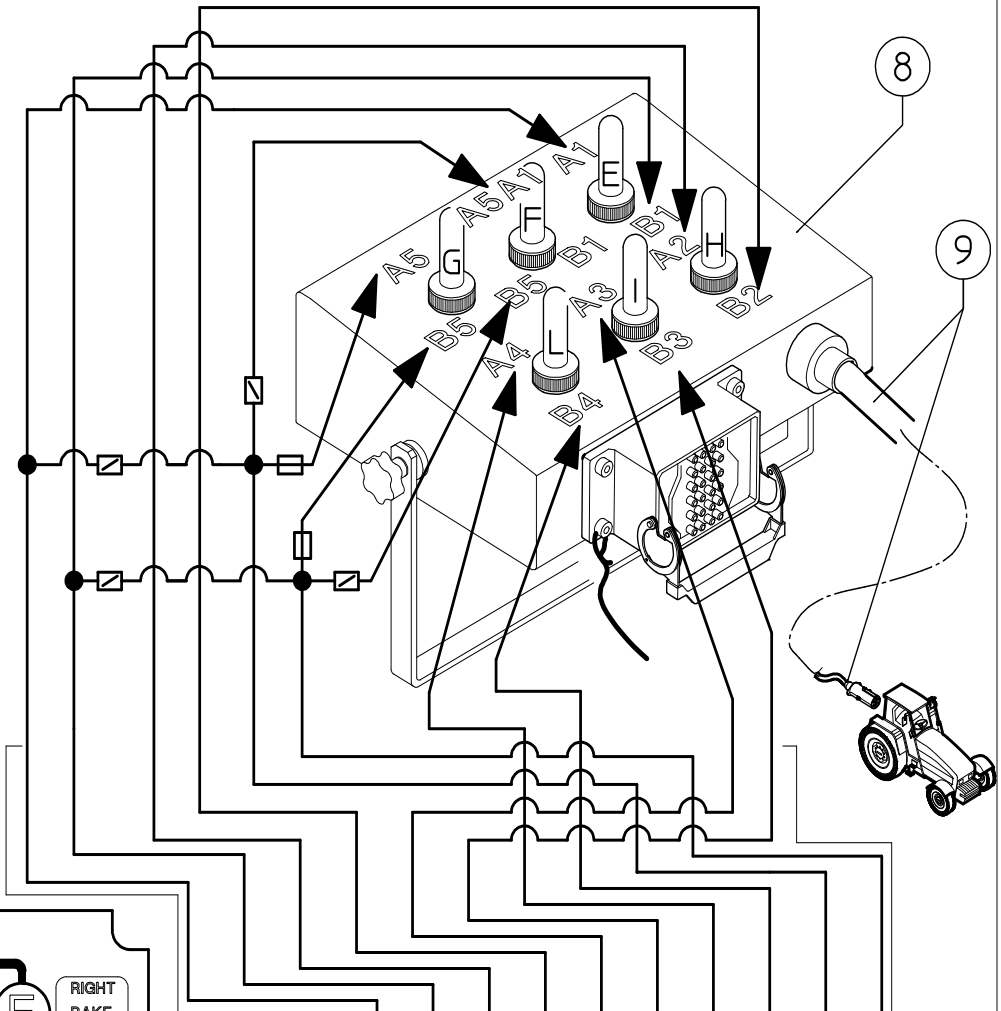
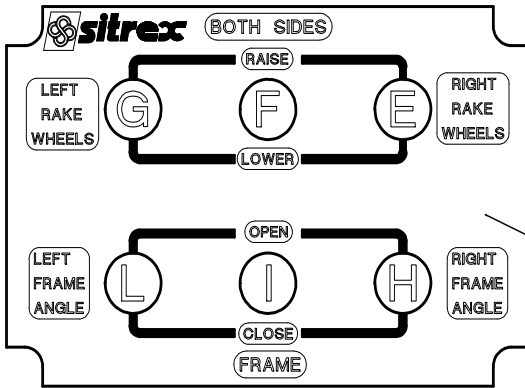
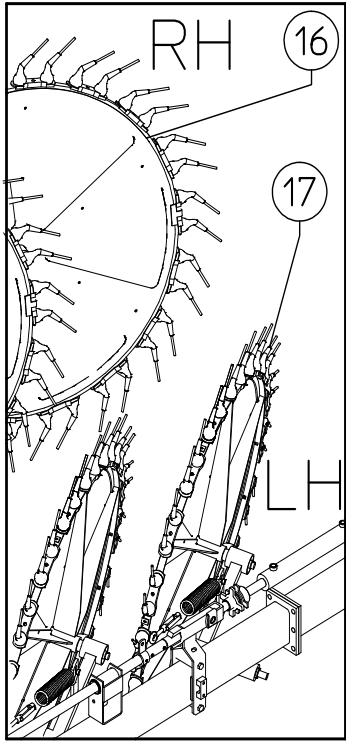

8) When button “H” (the one bearing the caption “RIGHT FRAME ANGLE” in control box 8) is pushed towards B2, it acts on coil 13 B2 which – through hose 14 B2 – sends oil to the front side B2 of RH cylinder 18, making it lower. The resulting effect is the transition of RH section 20 from the closed transport position to the open working position.

9) When button “I” (the one bearing the caption “FRAME CLOSE/OPEN” in control box 8) is pushed towards A3 (open), it acts on coil 13 A3 which – through hose 14 A3 – simultaneously sends oil through special joints to the back sides A3 of cylinders 19 (RH and LH), making them go up. The resulting effect is the simultaneous opening of RH and LH sides of the machine, shifting from the closed transport position to the open working position.

10) When button “I” (the one bearing the caption “FRAME CLOSE/OPEN” in control box 8) pushed towards B3 (close) acts on coil 13 B3 which – through hose 14 B3 – simultaneously sends oil through special joints to the front sides B3 of cylinders 19 (RH and LH), making them lower. The resulting effect is the simultaneous closing of RH and LH sides of the machine, shifting from the open working position to the closed transport position.

11) When button “L” (the one bearing the caption “LEFT FRAME ANGLE” in control box 8) is pushed towards A4, it acts on coil 13 A4 which – through hose 14 A4 – sends oil to the back side A4 of LH cylinder 18, making it go up. The resulting effect is the transition of LH section 21 from the open working position to the closed transport position.

12) When button “L” (the one bearing the caption “LEFT FRAME ANGLE” in control box 8) is pushed towards B4, it acts on coil 13 B4 which – through hose 14 B4 – sends oil to the front side B4 of LH cylinder 18, making it lower. The resulting effect is the transition of LH section 21 from the closed transport position to the open working position.

Point 18

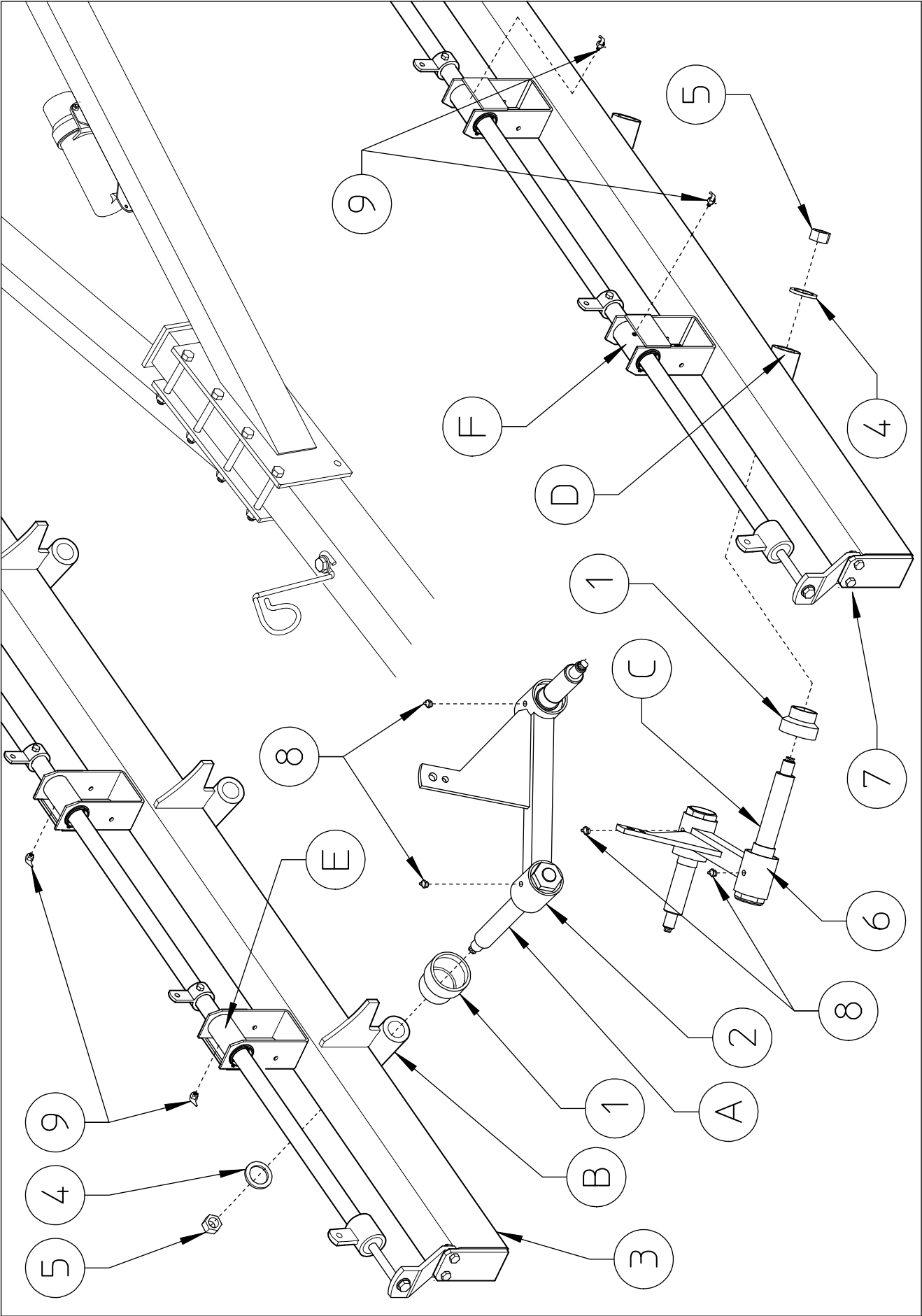

Point 18 (ATTENTION)

Attach protection 1 on pin “A” (the longer of the two) of RH arm 2. Attach pin “A” of RH arm 2 on the respective opening “B” of RH section 3. Fasten RH arm 2 to the opening “B” using washer 4 and nut 5 (the RH arms 2 to be connected to the openings “B” of RH section 3 are nine.)

Attach protection 1 on pin “C” (the longer of the two) of LH arm 6. Attach pin “C” of LH arm 6 to the opening “D” of LH section 7. Fasten LH arm 6 to opening “D” using washer 4 and nut 5 (the LH arms 6 to be connected to the openings “D” of LH section 7 are eight).

Assemble nipples 8 on the openings of arms 2-6 (RH and LH). Assemble nipples 9 on the openings “E-F” of sections 3-7 (RH and LH).

In this step, you will use:

Item 4: n° 17 ϕ 23-50x4 (ϕ 0.91”-1.97”x0.16”)

Item 5: n° 17 nut M22 (0.87”)

Item 8: n° 34 grease nipple M6 (0.24”)

Item 9: n° 17 grease nipple M6 x 45° (0.24” x 45°)

Point 19

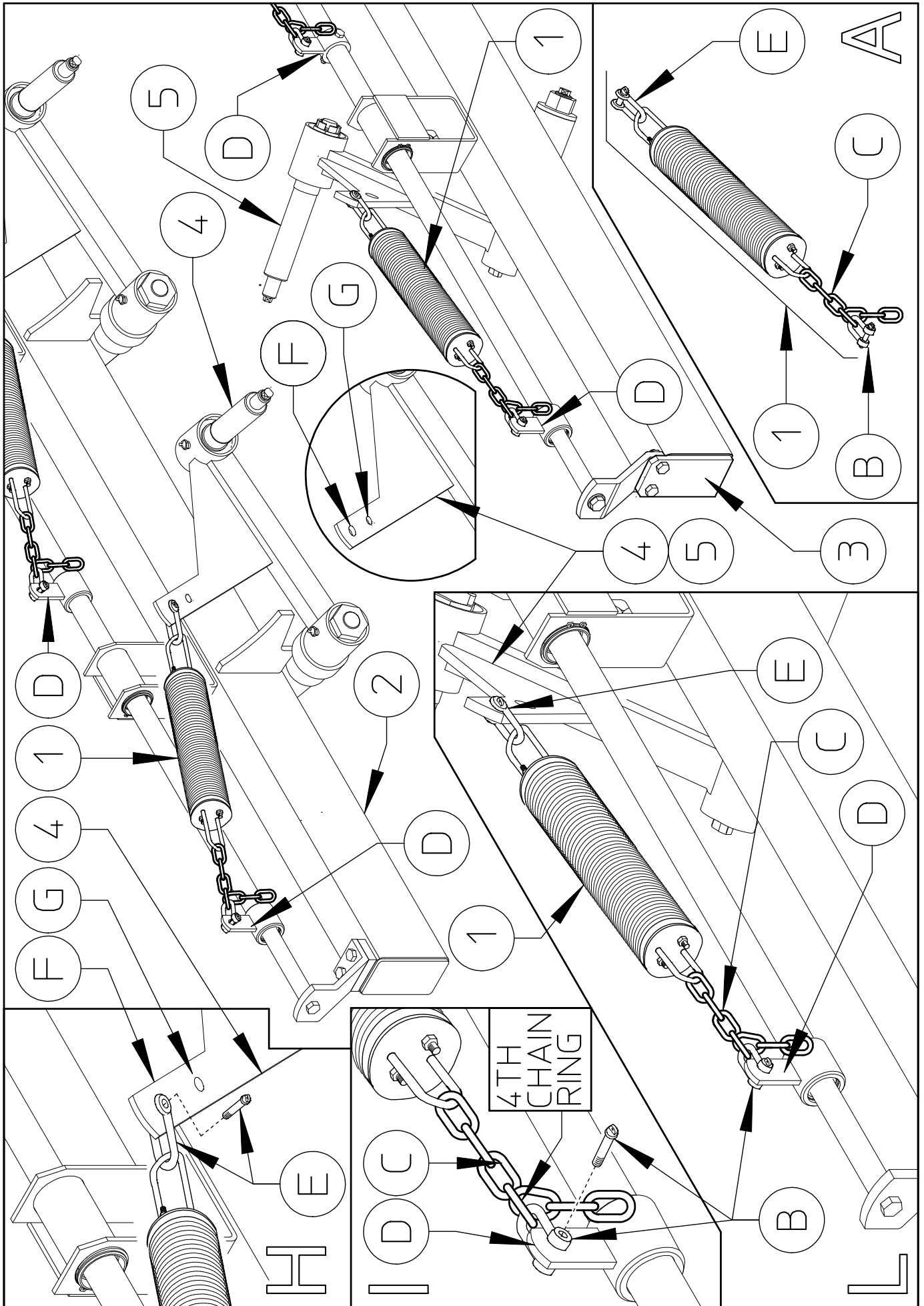

Point 19 (ATTENTION)

You have received seventeen spring pin assemblies 1 that have been pre-assembled by the manufacturer (see box “A”).

Every spring assembly consists of a set of parts such as the U-bolt “B” and chain “C”, which make it possible to hook onto brackets “D” on the rake wheel pipes on sections 2-3 (RH and LH), and U-bolt “E”, which makes it possible to hook onto holes “F” (the upper one) of the arm levers 4-5 (RH and LH). Besides these parts, described for assembly purposes, spring assembly 1 also consists of other parts, a complete list of which is found in the spare parts table 920.297.

Connect the side of spring assembly 1 that has the U-bolt “E” to hole “F” of the arm levers 4-5 (RH and LH) (see boxes “H”-“I”-“L”).

Connect the side of spring assembly 1 that has the chain “C” and the U-bolt “B” to brackets “D” on the rake wheel pipes on sections 2-3 (RH and LH) (see boxes “H”-“I”-“L”). Note: chain “C” has seven rings and U-bolt “B” was connected by the manufacturer to the 4th link (the middle link) as it is that most suitable on average for the working stage. For special user needs, the U-bolt “B” can be connected to other links, just as U-bolt “E”, which is normally connected to hole “F” on the arm levers 4-5 can be connected to hole “G” (the lower hole) on the arm levers 4-5. The effects of the possible adjustments of spring assembly 1 are described on pages 68-69-70-71-72-73; however, we mention briefly that when fewer links of chain “C” are used, the arms 4-5 (and respective rake wheels) are lowered less (rake wheels light on the ground), but the arms 4-5 (and respective rake wheels) are held more firmly when they are raised for transport, whereas when more links of chain “C” are used, the opposite effect is obtained.

In this step, you will use:

Item 1: n° 17 spring assemblies

Point 20

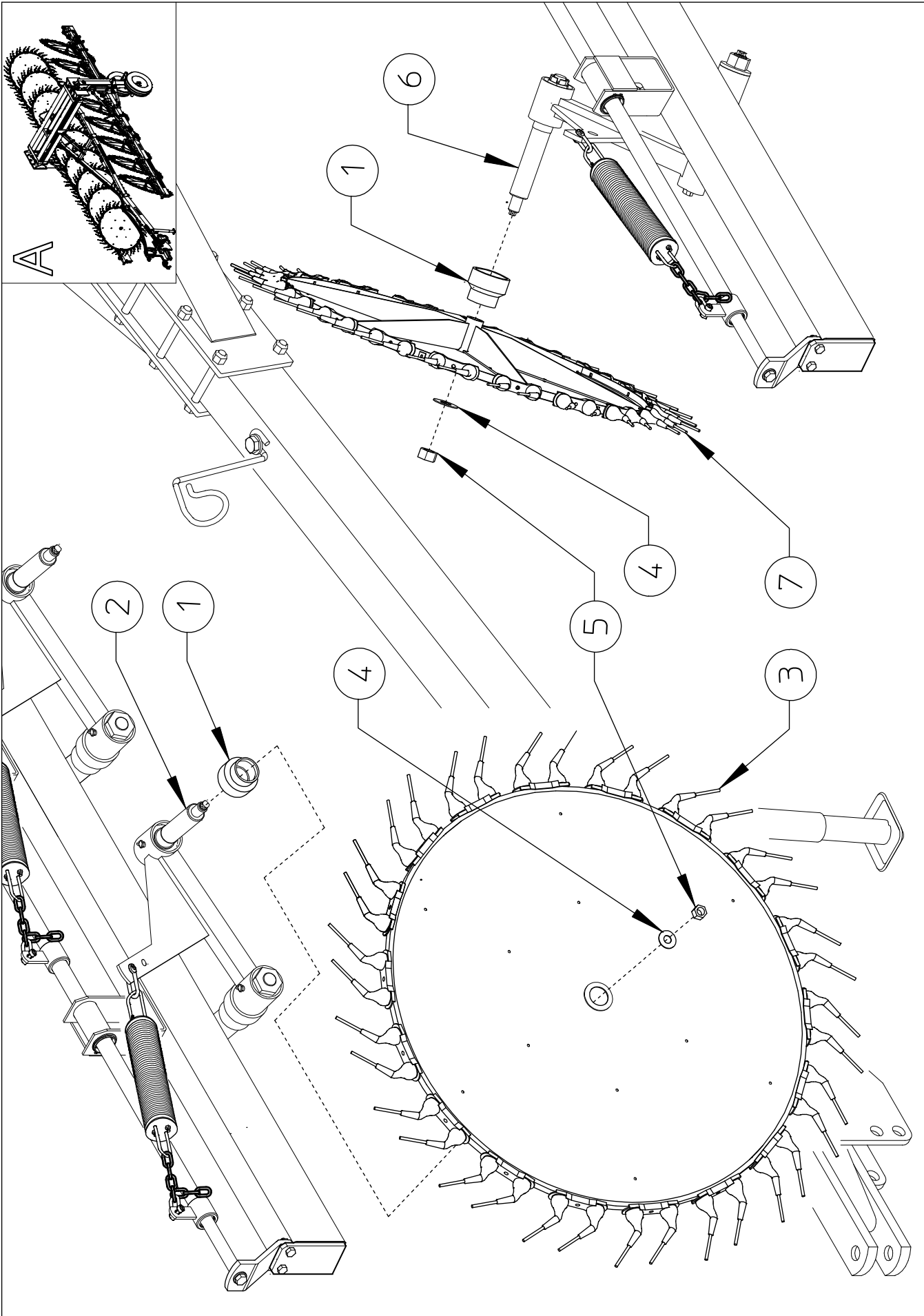

Point 20 (ATTENTION)

Attach protection 1 to the pin of RH arm 2. Connect the central washer of RH rake wheel 3 to the pin of RH arm 2 and fasten it with washer 4 and nut 5. There are nine RH rake wheels 3.

Attach protection 1 to the pin of LH arm 6. Connect the central washer of LH rake wheel 7 to the pin of LH arm 6 and fasten it with washer 4 and nut 5. There are eight LH rake wheels 7.

Now the machine is fully assembled and it appears as displayed in box "A".

In this step, you will use:

Item 1: n° 34 protection

Item 4: n° 17 washer $\varnothing 23-50 \times 4$ ($\varnothing 0.91''-1.97'' \times 0.16''$)

Item 5: n° 17 nut M22 (0.87'')

5) ADJUSTMENT, PREPARATION AND USE

INTRODUCTION

Connection to the tractor is highly dangerous. Take great care and carry out the entire operation in strict compliance with the following instructions. Nobody should go near the area between the tractor and the machine. Check that all warning and danger signs are in place and legible. Check that the tractor is in good running order. Refer to the tractor operator's manual.

ATTACHMENT OF MACHINE TO THE TRACTOR

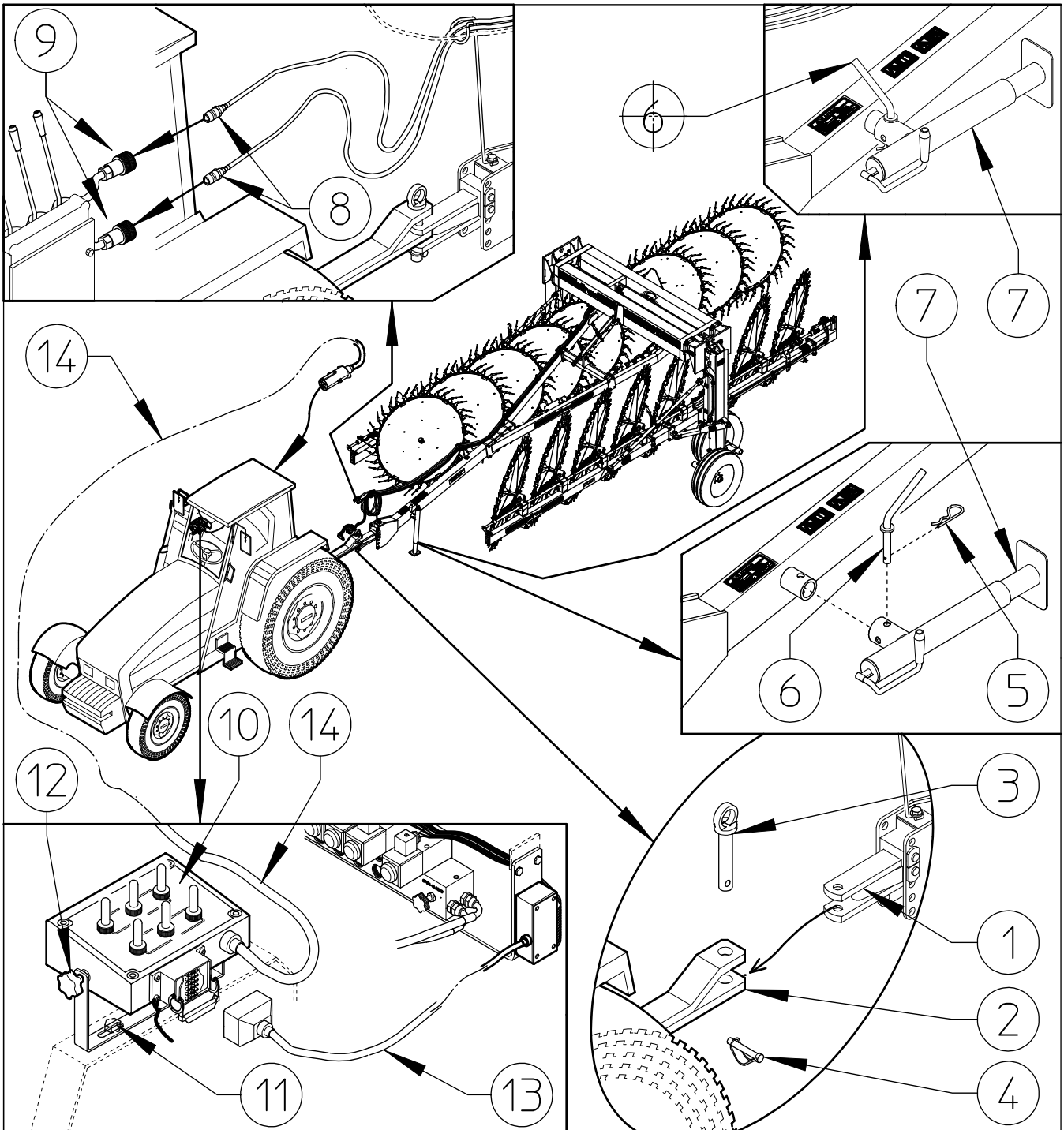

ATTACHMENT OF MACHINE TO THE TRACTOR

The attachment of machine to the tractor is very simple, as it is only necessary to couple the drawbar 1 to the tractor hitch 2 using pins 3 and 4 of appropriate size, strength and shape. Always use extreme care when reversing the tractor towards the machine. Once the machine is hitched to the tractor, the parking stand 7 must be raised from the parking position. To do this, remove clip 5 and pin 6, and rotate the parking stand 7 so that it is parallel to the ground. Fasten into the new position using pin 6 and clip 5.

Now connect the quick-release couplings 8 on the hydraulic circuit supply and return hoses to quick-release couplings 9 on the tractor. **To do this read carefully the information on pages 40-41-42-43-44-45-46-47.**

Firmly fasten the control box 10 in the cab, in an easily reached position that does not interfere with the other tractor controls, using the pre-drilled holes in bracket 11 of the box. The control box 10 can be oriented in the position most convenient for the operator using the knobs 12. At this point connect the multiple plug of the power cable 13 to the control box 10 and cable 14 of the multiple plug to the tractor. **To do this read carefully the information on pages 42-43-44-45.**

Before starting to move the components of the machine, we will briefly summarize the functions of the various buttons on the control panel. **To learn more about the various functions, read carefully the information on page 50-51-52-53.**

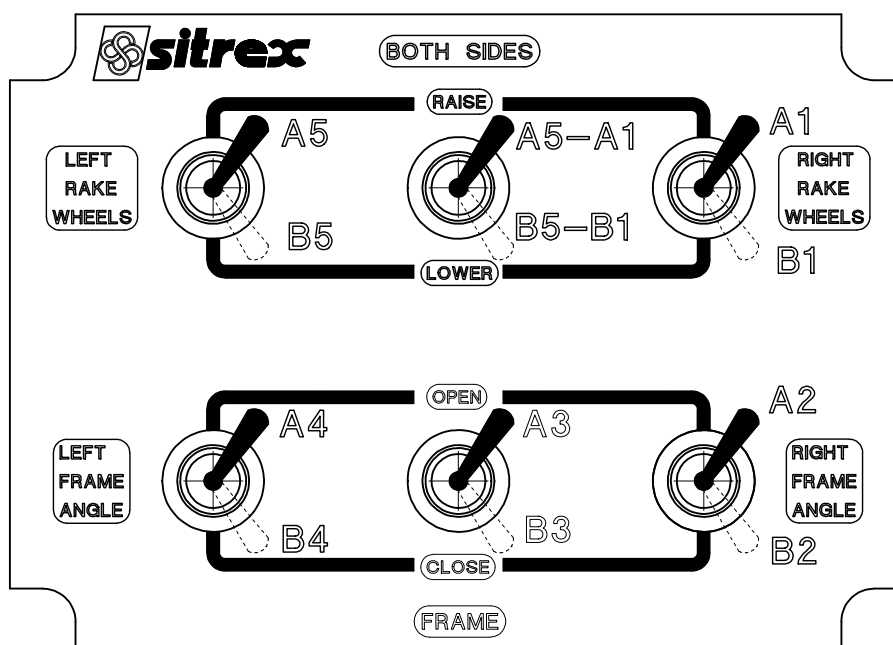

Button in A1: Raises the rake wheels on the right side of the machine
Button in B1: Lowers the rake wheels on the right side of the machine

Button in A5-A1: Raises the rake wheels on both sides of the machine
Button in B5-B1: Lowers the rake wheels on both sides of the machine

ATTACHMENT OF MACHINE TO THE TRACTOR

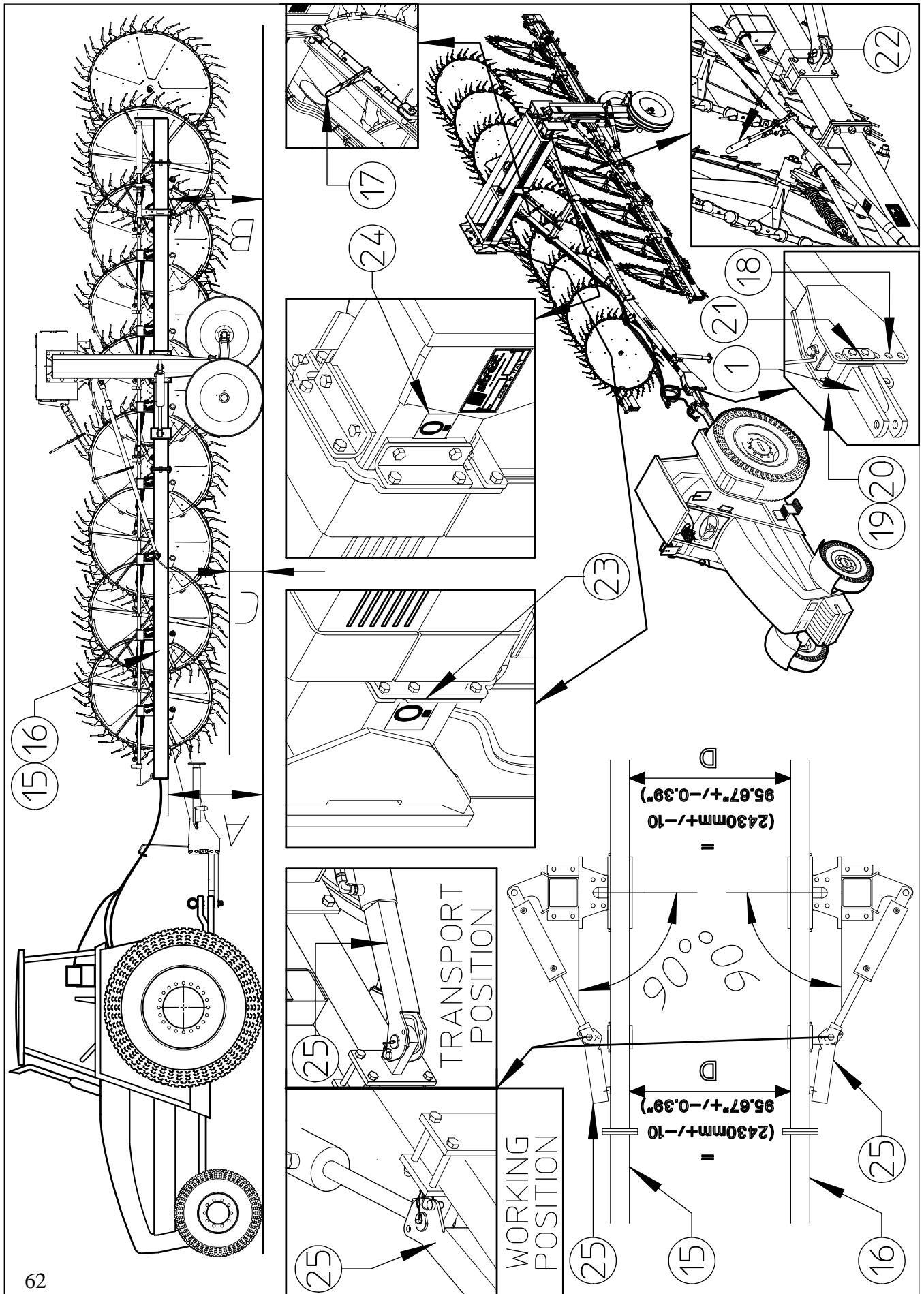

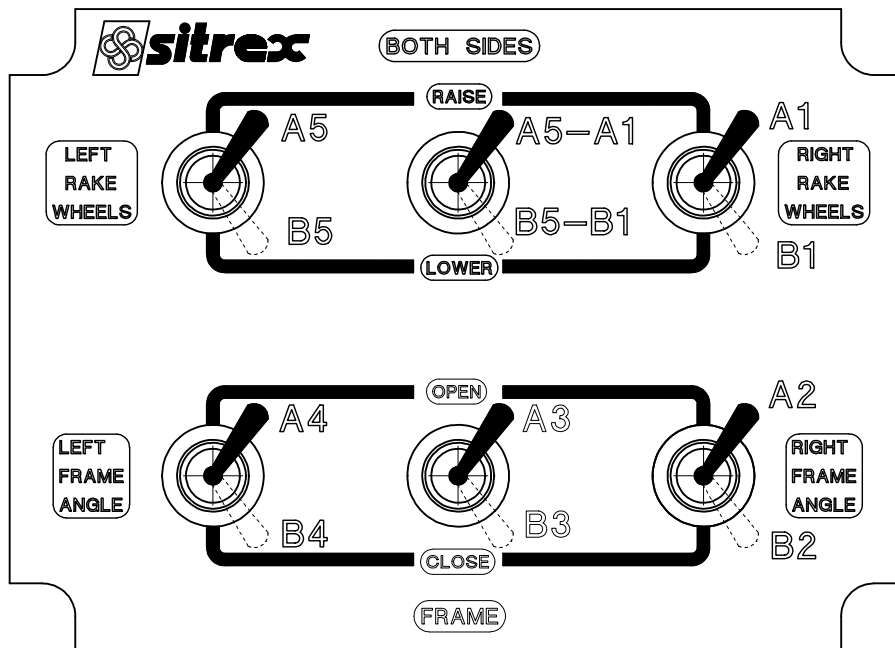

Button in A5: Raises the rake wheels on the left side of the machine
 Button in B5: Lowers the rake wheels on the left side of the machine

Button in A2: Closes the rake section on the right side of the machine
 Button in B2: Opens the rake section on the right side of the machine

Button in A3: Opens the sliding crosspieces on both sides of the machine
 Button in B3: Closes the sliding crosspieces on both sides of the machine

Button in A4: Closes the rake section on the left side of the machine
 Button in B4: Opens the rake section on the left side of the machine

Before starting the machine to test its operation, do a first check to see if the machine is correctly positioned with respect to the tractor. To do this you must check to see that the rake sections 15-16 (RH and LH) are parallel to the ground or slightly higher in front, i.e. height A (890mm-35.04" +10mm-0.4") must be equal to or slightly greater than height B (890mm-35.04" -10mm-0.4"). If this is not so, you have two ways to obtain the correct condition: either adjust the link 17 accordingly or move the tractor hitch 1 to holes 18 on the bar. The hitch 1 is moved by removing screws 19, washers 20 and pins 21 from the position given. After choosing the correct position, refasten all with pins 18, washers 20 and screws 19 (see pages 20-21).

Check also that links 22 hold up rake sections 15-16, otherwise shorten the links by moving the levers (see pages 32-33).

Now test the functionality of the machine, remembering, as mentioned earlier, that this must be done in a suitable space and with nobody within the operating radius of the machine. **For all the information on how to test the functionality of the machine, read carefully pages 44-45-46-47-48-49-50-51-52-53.**

ATTACHMENT OF MACHINE TO THE TRACTOR

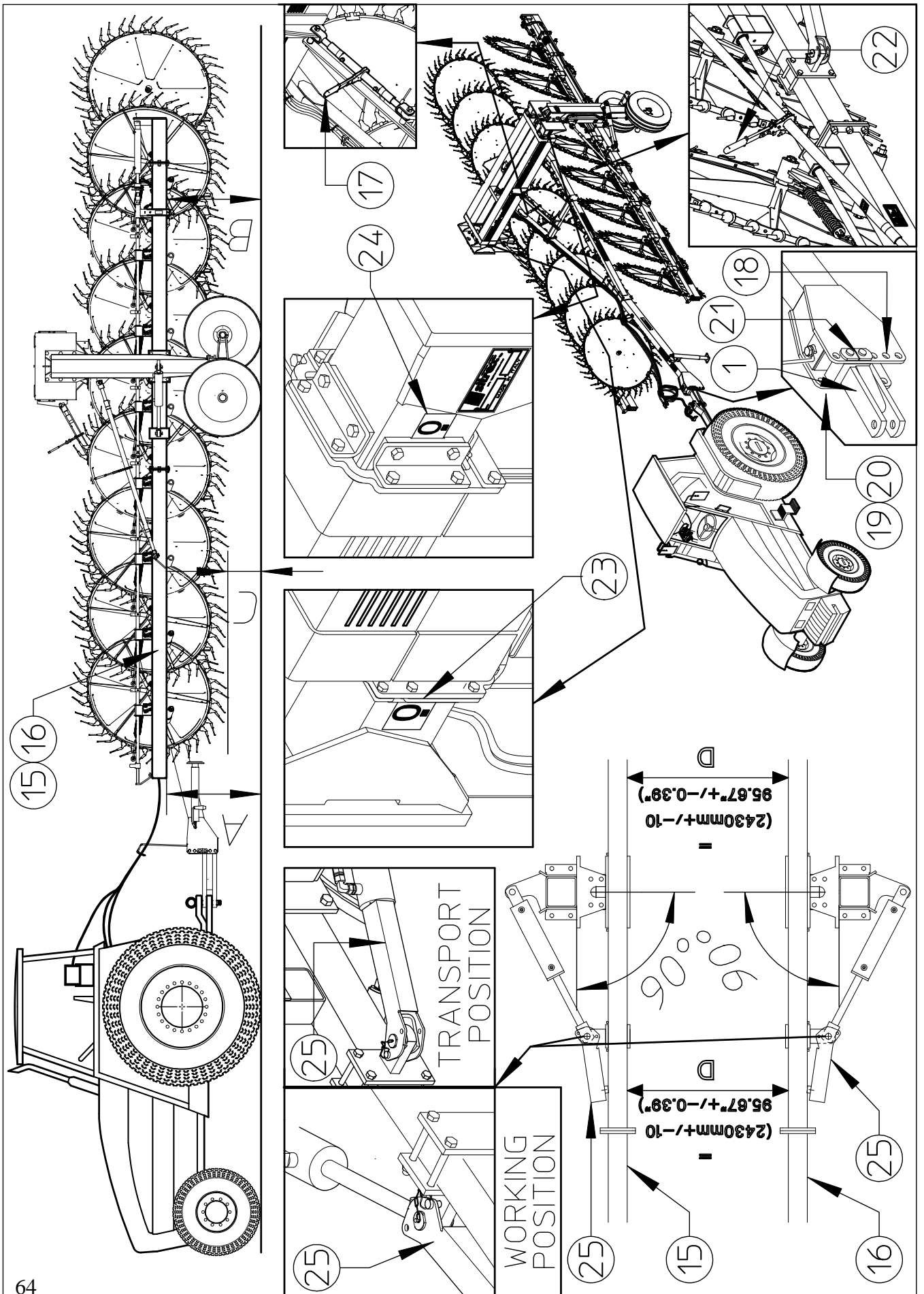

ATTACHMENT OF MACHINE TO THE TRACTOR

Now that the machine has been started, do the final check of the correct set up and functioning. If everything is right, the machine must be configured as follows for transporting:

rake wheels raised to a height of “C” approximately equal to $340\text{mm} \pm 10 - 13.39'' \pm 0.4''$ (if this is not the case, see pages 54-55-56-57-68-69-70-71), rear crosspieces completely closed, i.e. on the 0 on the graduated scale, rake sections 15-16 parallel with each other at a width “D” of about $2430\text{mm} \pm 10 - 95.67'' \pm 0.39''$ (if this is not the case, see pages 34-35). The safety arms 25 must be in the transport position on both sides. To move the safety arms, see pages 34-35-62-63.

If everything is set up like this, the machine is correctly assembled and looks like the illustration in Fig. 1 (see page 66), and you can proceed with transport.

Fig.1 – Machine set up for transport

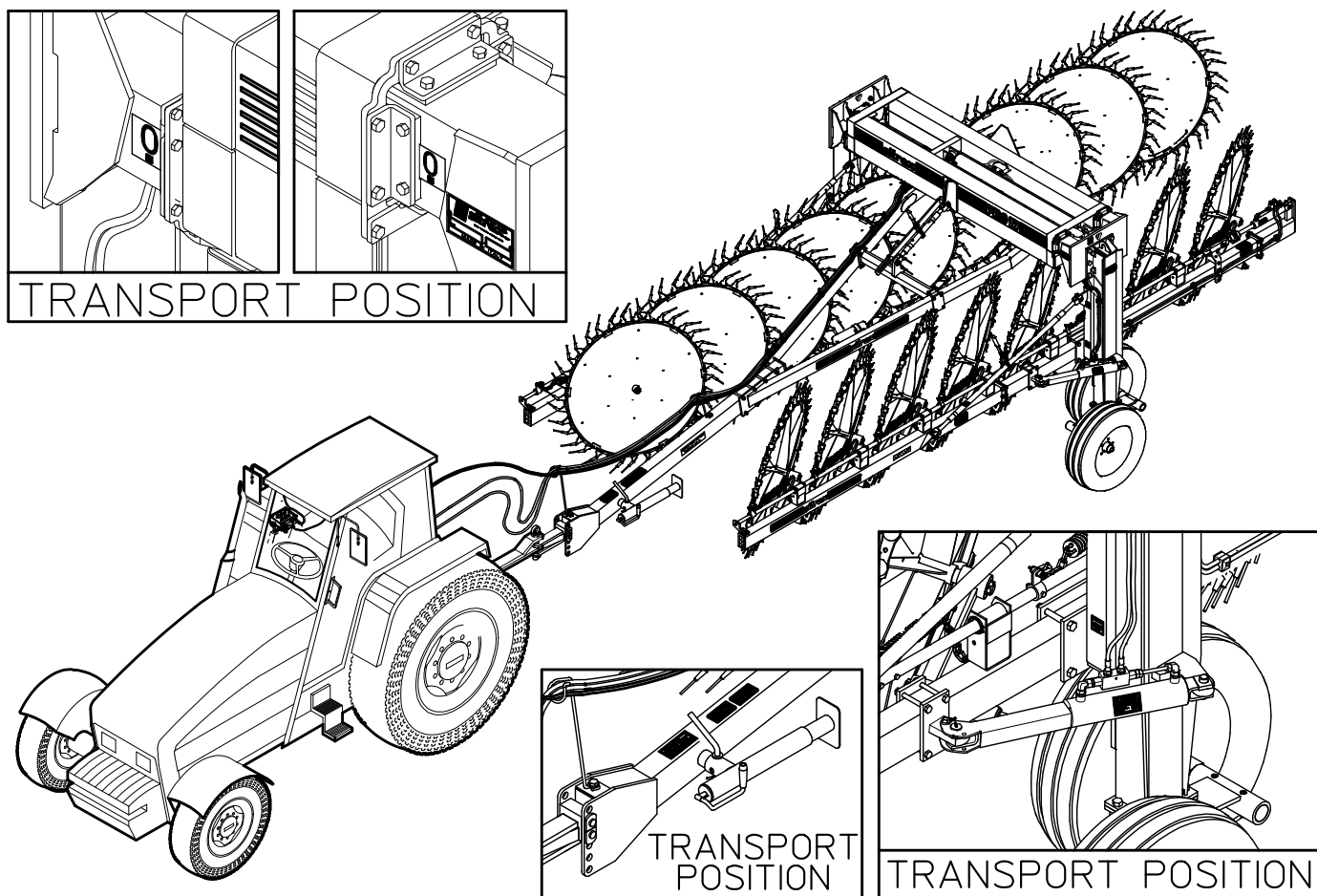

TRANSPORT BY ROAD

After the machine has been attached to the tractor as previously described and before transporting it to or from fields or any other workplace, the following instructions should be heeded:

Before setting off with the machine attached to the tractor, check the local road transport regulations. During transport keep the machine fully raised with the power takeoff disengaged and the lifting unit immobilised. Check that all guards, safety protection and locking split pins are in place, functioning and correctly fitted. Ensure that nobody leans against, or climbs on to, the machine during transport. Consult the tractor maintenance and use manual where necessary. Maintain constant control over the vehicle and ensure that you know how to stop the tractor quickly and switch off the engine. When on a public road, observe all highway code regulations. Drive near the edge of the road and try not to obstruct traffic. Do not park the tractor and/or the machine where it might obstruct, or be a danger to, any public right of way. Avoid going onto a public road if the tractor or machine is very dirty you could leave a trail of soil, grass and other matter which could dirty the road and obstruct normal traffic.

USE IN THE FIELD

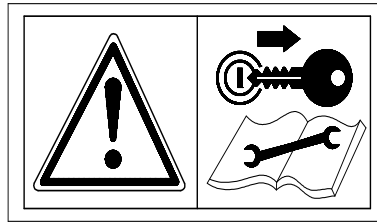
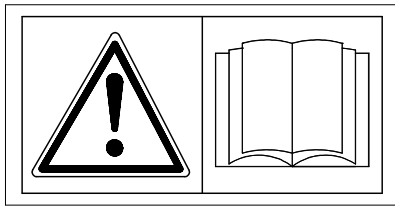

GENERAL INSTRUCTIONS FOR FIELD

Before starting work, familiarise yourself with the following general instructions:

Before using the machine ensure that all safety precautions are taken.

Check that all safety protection and guards are in place and working.

Inspect the work site in order to familiarise yourself with the terrain.

Do not start the tractor before being properly seated in the driving position.

Do not start the machine if it is damaged (or even if you only suspect it is damaged) and inform your nearest dealer of the problem and ask for assistance.

Do not allow yourself to become distracted when working give your full attention to the job in hand.

Maintain constant control over the tractor and ensure that you know how to stop quickly and switch off the engine.

Caution when working on inclines. It is better to work from the bottom to the top of an incline (or from the top to the bottom), rather than across an incline where there is a risk of overturning. Check and heed the instructions supplied by the tractor manufacturer, especially those concerning the maximum incline on which it is possible to work.

It is advisable to reduce speed when working and manoeuvring on inclines and only to change speed and direction gradually.

Do not make sudden stops or starts.

Do not work on wet or slippery grass or terrain, or anywhere where grip is poor. If this is unavoidable, work at a slow speed so as to ensure operator safety.

Always switch off the tractor engine, apply the parking brake and remove the ignition key whenever you have to attend to the machine to make adjustments or to remove grass and other objects which might be entangled in the machine.

Do not use the control levers as handholds since they can move and do not give a secure grip. Furthermore, any involuntary movement of a control lever can cause unintentional movement of the tractor or machine.

USE IN THE FIELD

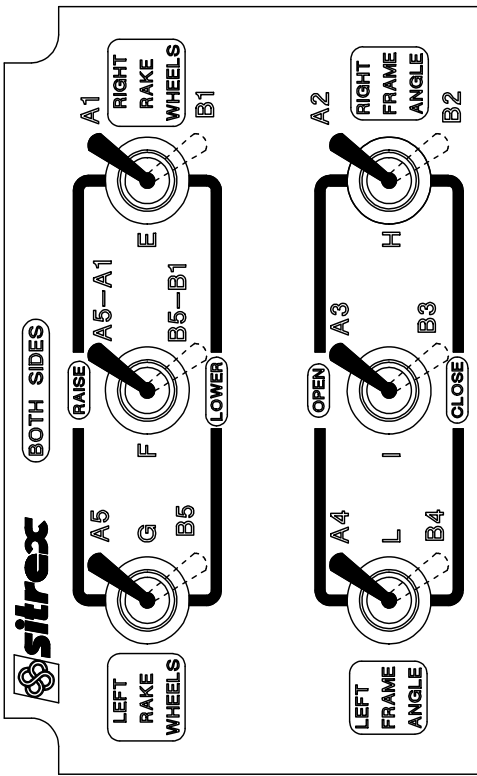
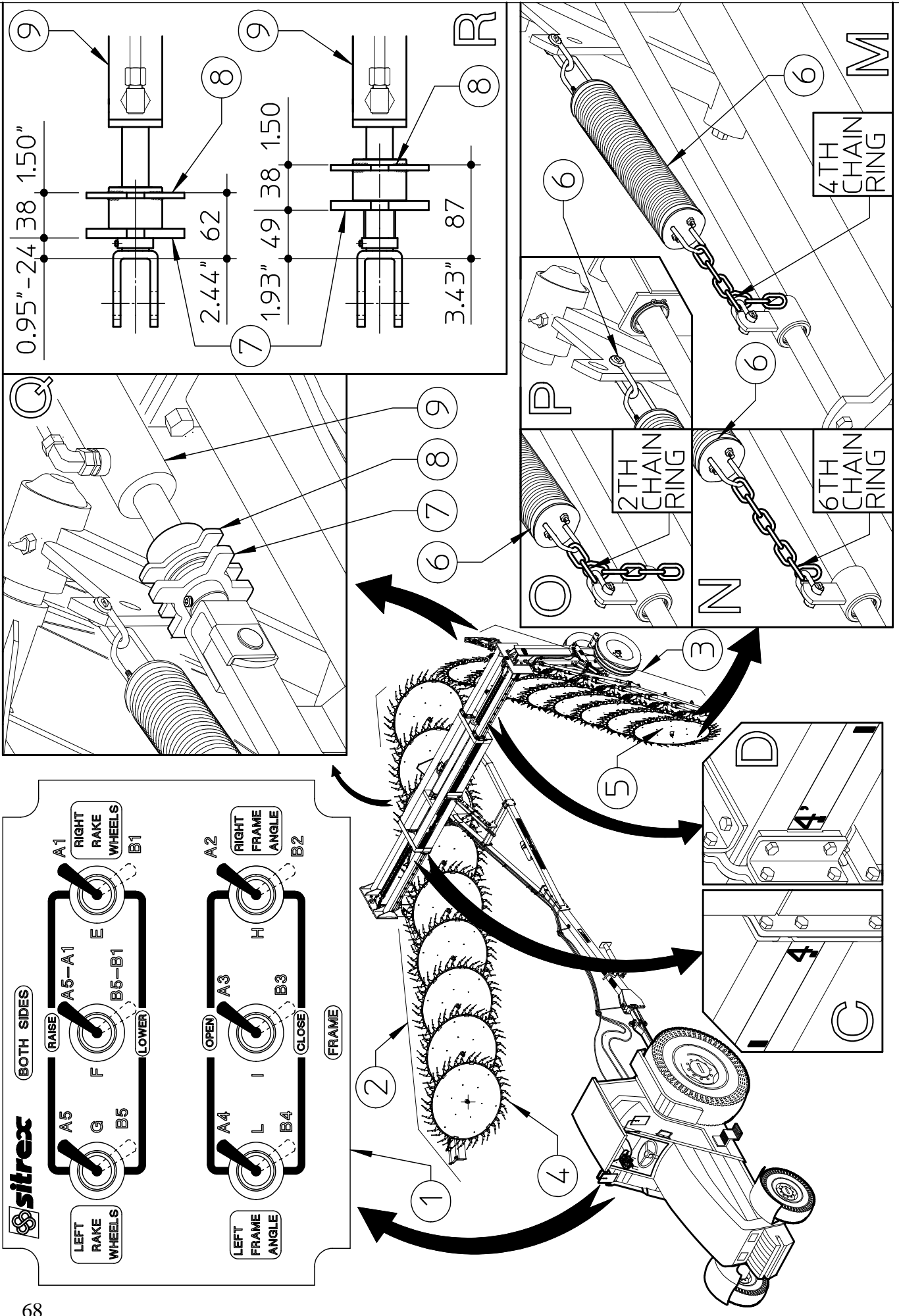

USE IN THE FIELD

Before starting work, we will briefly summarize the functions of the various buttons on the control panel 1. To learn more about the various functions, **read carefully the information on pages 44-45-46-47-48-49-50-51-52-53.**

Button E in A1: Raises the rake wheels on the right side of the machine

Button E in B1: Lowers the rake wheels on the right side of the machine

Button F in A5-A1: Raises the rake wheels on both sides of the machine

Button F in B5-B1: Lowers the rake wheels on both sides of the machine

Button G in A5: Raises the rake wheels on the left side of the machine

Button G in B5: Lowers the rake wheels on the left side of the machine

Button H in A2: Closes the rake section on the right side of the machine

Button H in B2: Opens the rake section on the right side of the machine

Button I in A3: Opens the sliding crosspieces on both sides of the machine

Button I in B3: Closes the sliding crosspieces on both sides of the machine

Button L in A4: Closes the rake section on the left side of the machine

Button L in B4: Opens the rake section on the left side of the machine

Keep in mind that before using buttons H-L in positions B2-B4 on the control panel 1 (those that open the rake sections 2-3), the sliding crosspieces must be opened (see boxes C-D) to the maximum width of 4' using button I in position A3. Do this if possible with the machine in movement or in any event on a surface that allows the transversal movement of the wheels. This is to avoid having the rake sections 2-3 knock against each other at the rear of the machine. If for working requirements you wish to open the sliding crosspieces less, then the rake sections 2-3 must also be opened less.

Recap of the operations to be carried out to put the machine in working position:

-Push button I into position A3 (FRAME-OPEN) until the sliding crosspieces open to the maximum width of 4' (see box C-D).

- Push button H into position B2 (RIGHT FRAME ANGLE) until the right rake section 3 opens completely.

- Push button L into position B4 (LEFT FRAME ANGLE) until the left rake section 4 opens completely.

USE IN THE FIELD

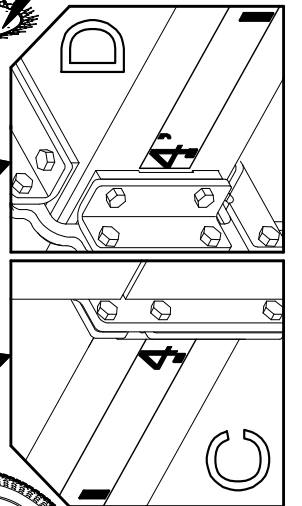
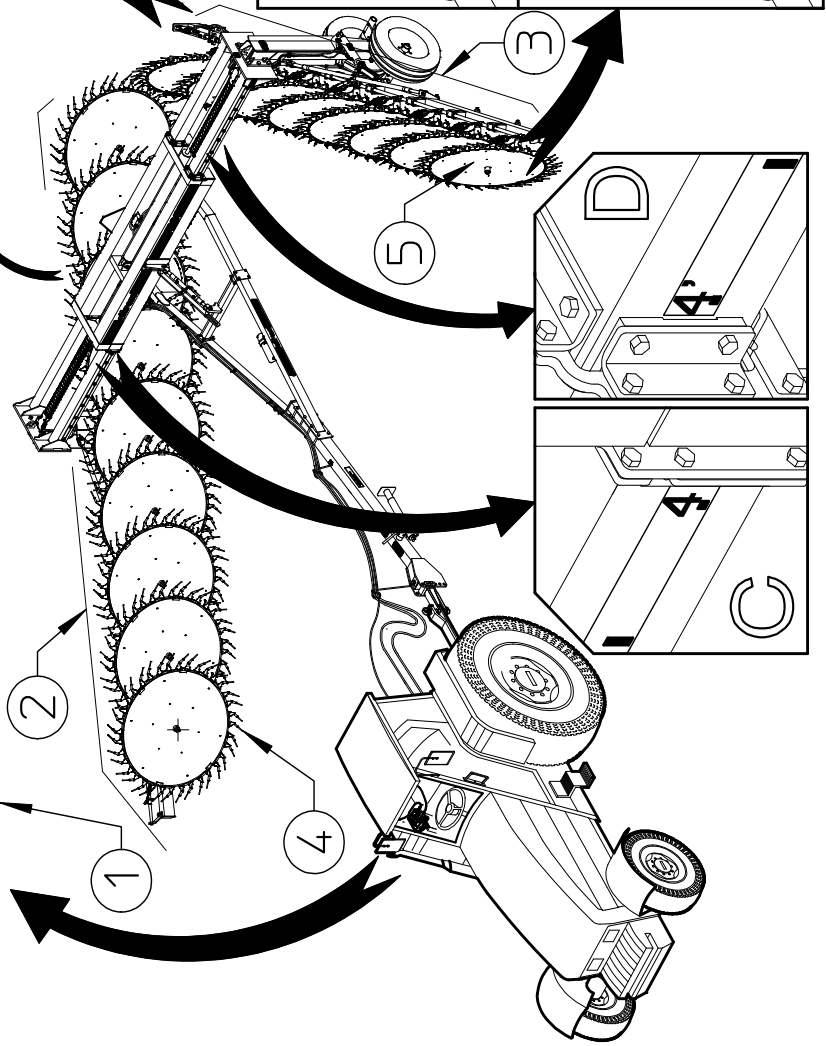
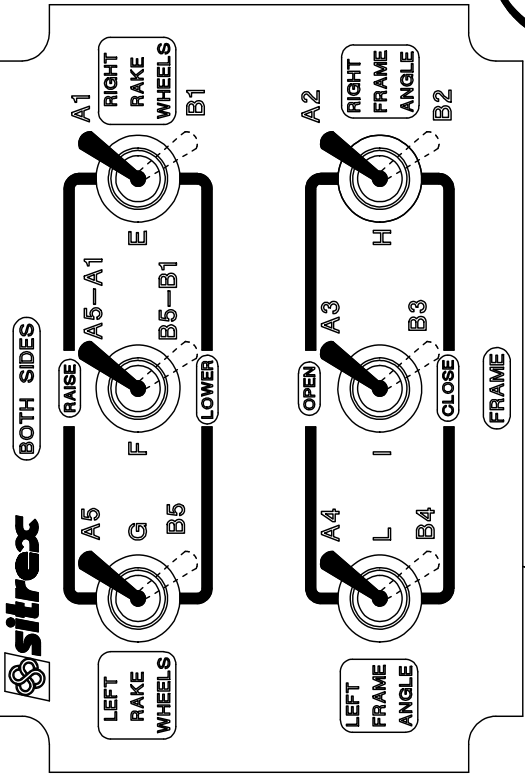
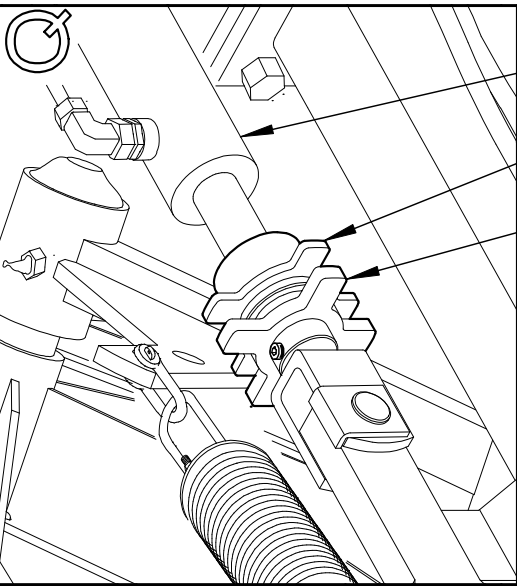
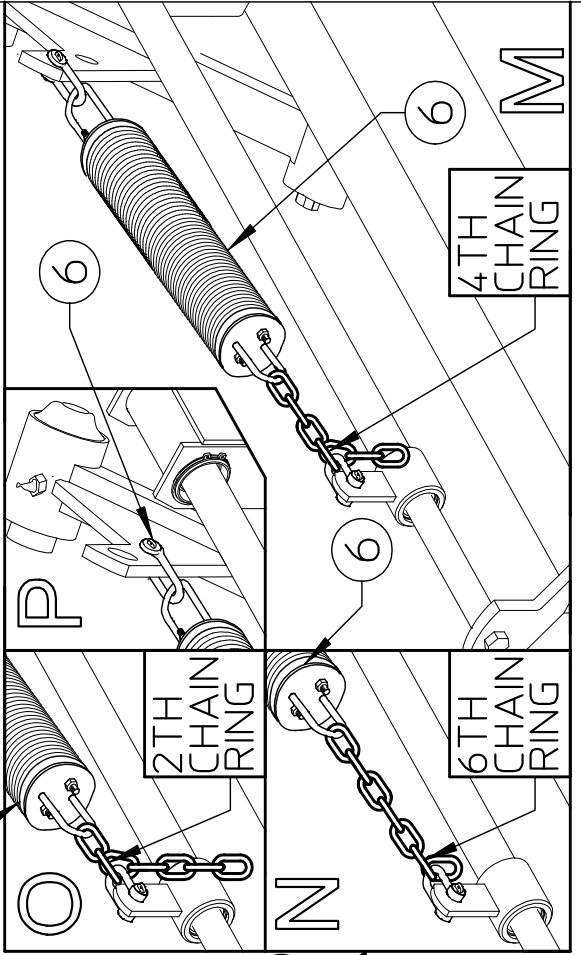
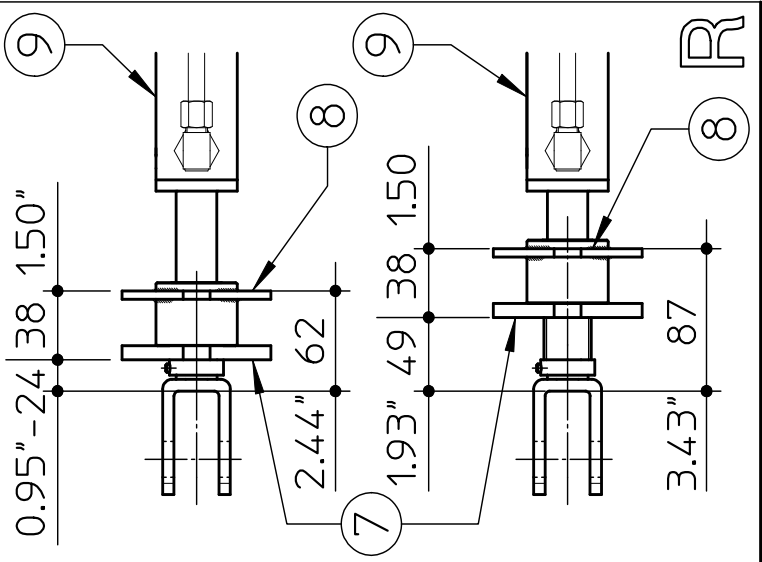

- Push button F into position B5-B1 (BOTH SIDES-LOWER) until the rake wheels 4-5 of rake sections 2-3 lower and touch the ground. For working requirements the lowering (or the raising) of the finger wheels can also be done on one side only or on one side more or less than on the other. In this case push button E (RIGHT RAKE WHEELS) into position B1 to lower and position A1 to raise the rake wheels 4-5 of right rake section 2 and button G (LEFT RAKE WHEELS) into position B5 to lower and position A5 to raise the finger wheels of left rake section 3.

With the machine thus set up, start working, and after the first runs check that the work has been done correctly. If any adjustments are needed, do the following:

If rake wheels 4-5 of rake sections 2-3 are too light on the ground (they do not collect all the hay), or are too heavy (they dig into the soil), some adjustments must be made to spring assemblies 6 (see boxes M-N-O-P). Before starting the adjustments to spring assemblies 6, place the machine on a flat, level surface and then check that the ring nuts 7-8 of cylinders 9 (see boxes Q-R) are in contact with each other in the minimum degree of 38 mm – 1.50” .

If the rake wheels 4-5 leave hay uncollected, they must be adjusted to be heavier on the ground. To do this, the chain of spring assemblies 6 must be moved from the 4th link (see box M) as set by the manufacturer, or from whatever link was being used, to the 6th link (see box N). Connection to the 6th link as shown in box N is an example, and the operator may choose another more suitable link, bearing in mind that the longer the chain is in spring assembly 6, the heavier are the rake wheels 4-5.

If rake wheels 4-5 dig into the soil, the contact with the ground must be lightened. To do this, the chain of spring assemblies 6 must be moved from the 4th link (see box M) as set by the manufacturer, or from whatever link was being used, to the 2nd link (see box O). Connection to the 2nd link as shown in box O is an example, and the operator may choose another more suitable link, bearing in mind that the shorter the chain is in spring assembly 6, the lighter are the rake wheels 4-5.

At this point, if you want the rake wheels 4-5 to return to the same position every time they are lowered, adjust the movable ring nut 8 until it is in contact with the head of cylinder 9, then lock in place with ring nut 7. Note: the maximum limit allowed by the ring nuts 7-8 is 87 mm-3.43”. In addition, the ring nuts 7-8 of cylinders 9 allows the making of small adjustments to the pressure of rake wheels 4-5 without having to move the chains of spring assemblies 6 (a more complex operation), bearing in mind the concept that the more the distance of ring nuts 7-8 from the fork of cylinder 9 increases (do not go beyond the maximum limit of 87 mm-3.43”), the lighter are the rake wheels 4-5; vice versa, the more the distance of ring nuts 7-8 decreases, the heavier are the rake wheels 4-5.

To avoid having the setting shift, once the adjustment is made, ring nuts 7-8 must be in forced contact in the minimum degree of 38 mm-1.50” (see box R).

USE IN THE FIELD

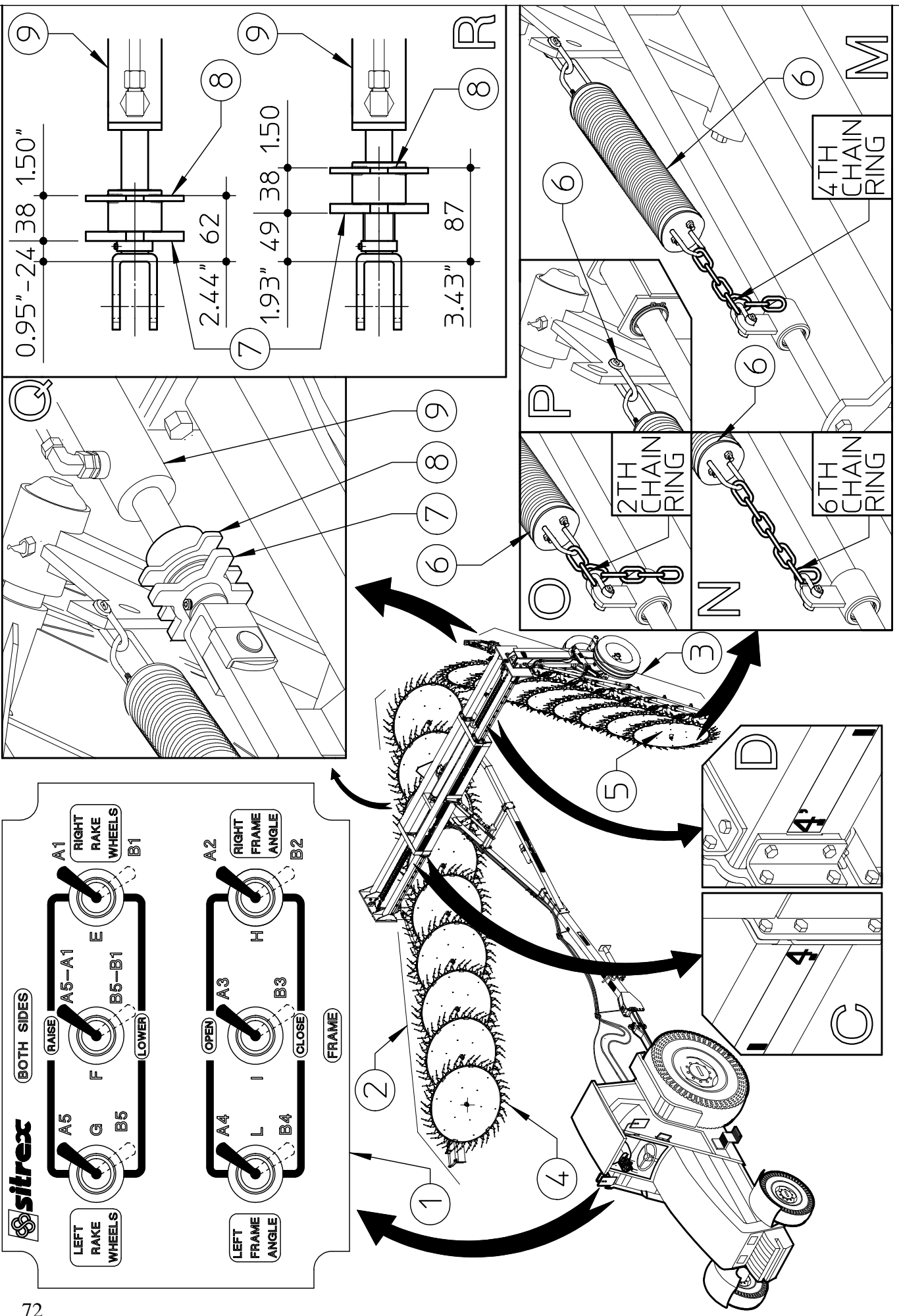

Another possible adjustment of the pressure against the ground of rake wheels 4-5 can be done (see box P) by moving the attachment of the spring assembly 6 from the upper hole to the lower hole of the rake wheel arms. In this case, with all other adjustments remaining the same, one obtains both a greater weight on the ground of rake wheels 4-5 as well as greater stability during transport.

Bear in mind that any adjustment you do to the rake wheels on the ground will also affect the transport conditions, according to the concept that the lighter rake wheels 4-5 are on the ground, the more stable they will be during transport; vice versa, the heavier rake wheels 4-5 are on the ground, the less stable they will be during transport. Therefore it is up to the operator to find the right compromise or to favor one of the two options, according to their needs.

MAINTENANCE DIRECTIONS

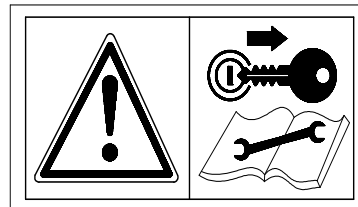
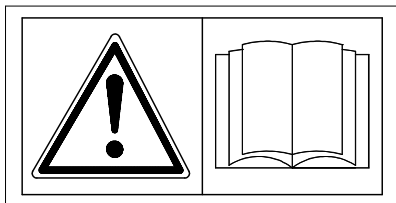

All cleaning, lubrication and maintenance operation must be carried out with the machine disconnected from the tractor.

In an emergency with the machine still connected to the tractor, switch off the engine, apply the parking brake, disengage the power takeoff and remove the ignition key from the instrument panel.

Regular, correct maintenance and proper operation are the basic prerequisites for the long-term efficiency and safe operation the machine.

Pay special attention to all instructions given on signs located on the machine.

All maintenance should be carried out in an area having the proper equipment readily available and in good condition.

This area must always be kept clean and dry and must have enough surrounding space to facilitate operations.

Any work must be carried out by trained personnel. Contact the dealer nearest to you. Respect the warnings and procedures for maintenance and technical assistance given in this manual.

Do not use petrol, solvents or other flammable liquids as detergents.

Use commercial non-flammable and non-toxic solvents, authorised by competent bodies.

Do not use compressed air or water at high pressure to clean the machine. If this is unavoidable, then wear goggles with side protection and limit the pressure as much as possible. When the work is finished, and with the machine disconnected from the tractor, inspect and check the machine completely.

MAINTENANCE POINTS

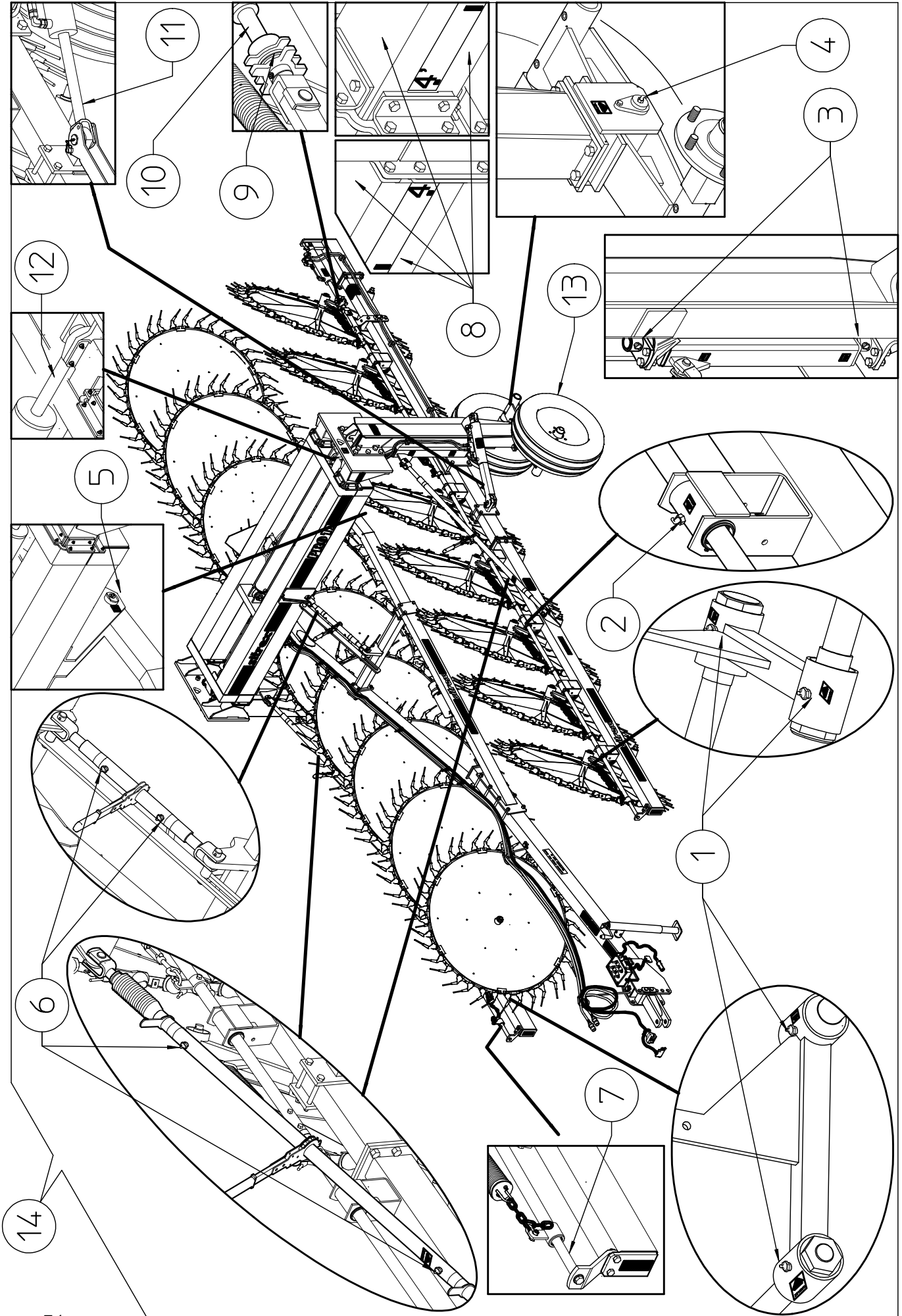

MAINTENANCE POINTS

ITEM	Q.ty	DESCRIPTION	OPERATION	Every hours	NOTES
1	34	RAKE WHEEL ARM	LUBRICATE	50	*
2	15	BUSHING	LUBRICATE	50	*
3	4	SECTION JOINT	LUBRICATE	50	*
4	2	TANDEM PIN	LUBRICATE	50	*
5	2	DRAWBAR PIN	LUBRICATE	100	*
6	6	RATCHET LINK	LUBRICATE	100	*
7	2	SUPPORT PIN	CLEAN/ LUBRICATE	*	SEE NOTE A
8	2	SLIDING CROSSPIECE	CLEAN/ LUBRICATE	*	SEE NOTE B
9	2	ADJUSTMENT SCREWS	CLEAN/ LUBRICATE	*	SEE NOTE C
10	2	RAKE WHEEL LIFTING CYLINDER	CLEAN/ LUBRICATE	*	SEE NOTE D
11	2	SECTION OPENING CYLINDER	CLEAN/ LUBRICATE	*	SEE NOTE E
12	2	CROSSPIECE OPENING CYLINDER	CLEAN/ LUBRICATE	*	SEE NOTE F
13	4	WHEELS	CHECK PRESSURE	*	SEE NOTE G
14	-	General checking of bolts, security pins and split pins to be carried out initially after the first 8 hours of use. Subsequently every 50 hours and whenever the machine is laid up for extended periods.			
GREASE TYPE : NGLI 1 (NGLI 2)					

A = Every time the machine is used again after a rest period clean and brush with grease. Do this also at the end of the season when the machine is put away, and also when it is used again the next year, as the grease loses its effectiveness due to atmospheric agents.

B = Every time the machine is used again after a rest period clean and brush with grease the faces of the sliding tubular elements. Do this also at the end of the season when the machine is put away and also when it is used again the next year, as the grease loses its effectiveness due to atmospheric agents.

C = Each time an adjustment is made it is a good practice to clean and brush with grease to facilitate sliding. Do this also after a rest period, at the end of the season when the machine is put away and when it is used again the next year, as the grease loses its effectiveness due to atmospheric agents.

D = When the machine is not being used, either between one working period and another and even more so during winter, leave the cylinders closed so that the shafts are not exposed to atmospheric agents. Leaving the cylinders closed means that the rake wheels rest on the ground and thus they do not weigh on the springs and on the support structure. If for any reason the cylinders remain extended, clean and brush the shafts with grease. When they are to be used again, either after a brief period or even more so after winter, check to see if there are traces of rust on the shafts. If so eliminate the rust being careful not to scratch the surface.

E = When the machine is not being used, either between one working period and another and even more so during winter, if due to limited space the rake sections are closed and thus the cylinders are completely extended and the shafts are exposed to atmospheric agents, clean and brush them with grease. When they are to be used again, either after a brief period or even more so after winter, check to see if there are traces of rust on the shafts. If so eliminate the rust being careful not to scratch the surface.

F = When the machine is not being used, either between one working period and another and even more so during winter, if due to limited space the sliding crosspieces are closed, in this case the cylinders are completely closed and thus the shafts are not subject to the action of atmospheric agents. If for any reason the cylinders remain extended, clean and brush the shafts with grease. When they are to be used again, either after a brief period or even more so after winter, check to see if there are traces of rust on the shafts. If so eliminate the rust being careful not to scratch the surface.

G = Each time that the machine is used, either between one working period and another and even more so during winter, check the pressure of the tires, which should be 35 psi.

GENERAL INSTRUCTIONS FOR REPAIR WORK

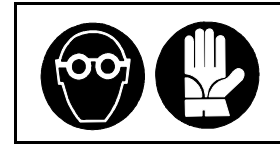
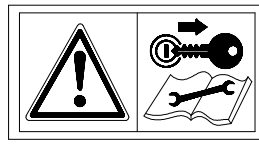
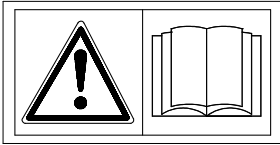

Any repair work must be carried out with the machine at rest and disconnected from the tractor.

Do not carry out welding without authorisation and instructions from the manufacturers.

Disconnect the machine from the tractor before any welding work in order not to damage the battery. Always use a protective mask, goggles and gloves when welding, sanding or grinding or when using a hammer or drill.

Always work on the machine out of doors. If you have to operate the machine when connected to the tractor in an enclosed are (for example when testing after repair and/or maintenance) ensure that there is sufficient ventilation so as to prevent noxious exhaust gases accumulating.

In order to acquire the necessary control and to operate in safety, practise various manoeuvres by simulating those required in the workplace with the help of an experienced person.

If you activate the machine while it is raised from the ground, make sure there is nobody standing nearby or in a dangerous position.

LAYNING UP FOR EXTENDED PERIODS

At the end of the season, or when an extended period of inactivity is envisaged, it is advisable to:

Clean the machine following instructions and allow it to dry.

Check it carefully and replace any damaged or worn parts.

Thoroughly tighten all screws and bolts.

Grease the machine thoroughly and then cover it completely and lay it up in a dry place.

It is to the user's advantage to carry out these operations carefully. In this way, he will have a machine in perfect condition when work is restarted.

On recommencing work, repeat all the proper checks so as to be certain of working in conditions of maximum safety.

NOISE AND VIBRATION

Noise affecting the tractor driver (from the machine only) is less than 80dB.

Vibration from the machine affecting the upper body and limbs of the driver is insignificant and is lower than the values given in Point 3.6.3 of Enclosure 1 of the Machine Directives (89/392/EEC, 91/386/EEC)

THE FOLLOWING SHOULD BE NOTED IF THE MACHINE IS SCRAPPED

The machine consists mainly of ferrous material, which must be disposed of according to the regulations in force in the country concerned.

There is also a small amount of plastic, which must be disposed of according to the regulations in force in the country concerned.

There is very small amount of residual grease, which must be disposed of according to the regulations in force in the country concerned.

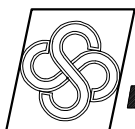

AGRICULTURAL MACHINERY
sitrex® SpA .

Zona Industriale-Viale Grecia, 8
06018 TRESTINA-(Perugia)-ITALY
Tel. +39.075.8540021-Telefax +39.075.8540523
e-mail: sitrex@sitrex.it www.sitrex.com

